

BAT-12SB40CL

LEAD ACID AGM BATTERY 12V 40AH DEEP CYCLE



12SB40CL 12Volt 40Ah

Specifications

Nominal Voltage(V) **12V**

Nominal Capacity

20 hour rate	(2A	to	10.50V)	40Ah
10 hour rate	(3.8A	to	10.50V)	38Ah
5 hour rate	(6.8A	to	10.20V)	34Ah
1 C	(40A	to	9.60V)	22.67Ah
3 C	(120A	to	9.60V)	16Ah

Weight **Approx. 13.1kg(28.82Lbs.)**

Internal Resistance (at 1KHz) **Approx. 7 mΩ**

Maximum Discharge Current for

5 seconds: **375A**

Charging Methods at 25 (77)

Cycle use:

Charging Voltage **14.4 to 15.0V**

Coefficient -5.0mv/ /cell

Maximum Charging Current : **12A**

Standby use:

Float Charging Voltage **13.50 to 13.80V**

Coefficient -3.0mv/ /cell

Operating Temperature Range

Charge **-15 (5) to 40 (104)**

Discharge **-15 (5) to 50 (122)**

Storage **-15 (5) to 40 (104)**

Charge Retention (shelf life) at 20 (68)

1 month **92%**

3 month **90%**

6 month **80%**

Case Material **ABS**

(Option: UL94 HB & UL94 V-0 flame retardant)

Terminal **F4**



Dimensions

mm(inch)

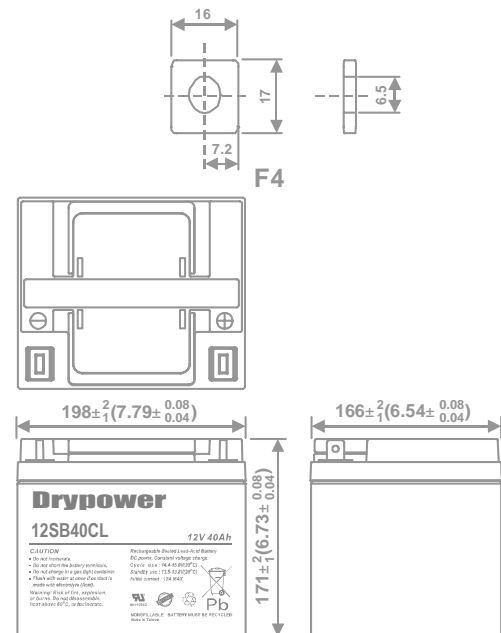

(v) Discharge Time VS. Discharge Current (25)

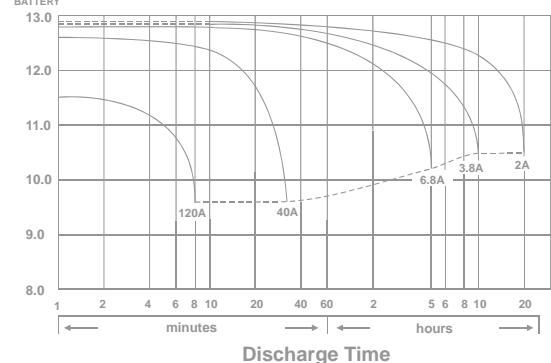

BAT-12SB40CL

LEAD ACID AGM BATTERY 12V 40AH DEEP CYCLE



Effect of Temperature on Capacity 25 (77)

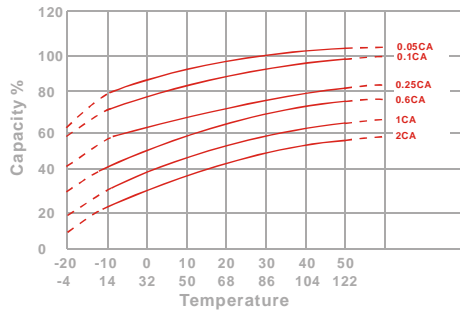

Capacity Retention Characteristic

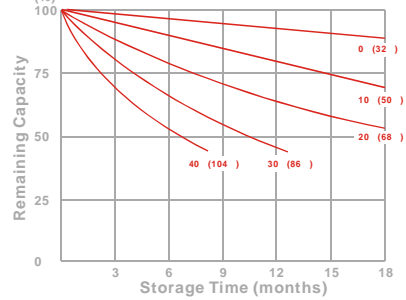

Trickle (or float) Service Life

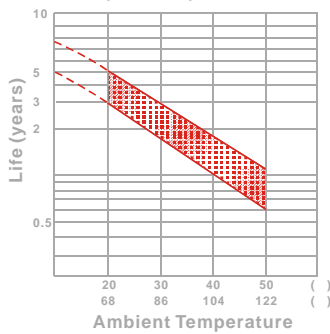

Cycle Service Life

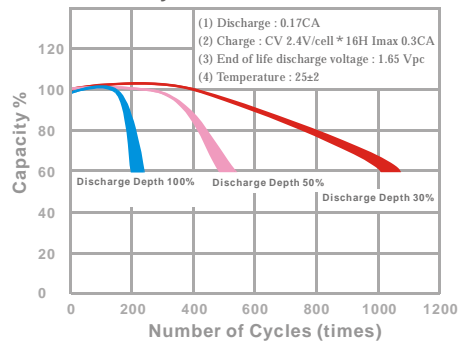

- PERFORMANCE DATA

Discharge Rates in Watts to Various End Voltages at 25 (77)

Time	End Voltage	11.10V	10.80V	10.50V	10.20V	9.90V	9.60V
5	min	1333	1604	1795	1919	1987	2022
10	min	856	1029	1152	1232	1275	1298
15	min	663	781	862	913	942	957
30	min	354	416	459	487	502	510
60	min	262	270	272	274	277	279
120	min	138	143	144	144	146	147
180	min	110	114	114	115	116	117
240	min	88.4	91.2	92.0	92.4	93.5	94.2
300	min	75.1	77.6	78.2	78.5	79.5	80.1
600	min	44.4	45.8	46.2	46.4	46.9	47.3
1200	min	22.7	23.5	24.0	24.4	24.6	24.7

- Discharge Rates in Amperes to Various End Voltages at 25 (77)

Time	End Voltage	11.10V	10.80V	10.50V	10.20V	9.90V	9.60V
5	min	119	143	160	171	177	181
10	min	74.4	89.5	100	107	111	113
15	min	56.5	66.4	73.3	77.7	80.2	81.4
30	min	29.7	35.0	38.6	40.9	42.2	42.9
60	min	21.9	22.6	22.8	22.9	23.2	23.4
120	min	11.5	11.9	12.0	12.0	12.2	12.3
180	min	9.13	9.43	9.50	9.55	9.66	9.73
240	min	7.30	7.54	7.60	7.64	7.73	7.79
300	min	6.21	6.41	6.46	6.49	6.57	6.62
600	min	3.65	3.77	3.80	3.82	3.86	3.89
1200	min	1.92	1.98	2.00	2.02	2.03	2.04

All data on the spec. sheet is an average value:

The tolerance range : X<6min(+15%~-15%), 6min X<10min(+12%~-12%),10min X < 60min(+8%~-8%), X 60min(+5%~-5%)