



* **NOTE:** Some models do not have front panel switches /LED indication

Ideal as Standby Float Charger for lead acid batteries



◆ 24 Month Warranty

- Suitable for power supply or battery charging
 - Conservative design for long life
 - Easy installation with many options
 - Wide input voltage window tolerance
 - Precise voltage and current controls
 - Efficient modern 'current-mode' topology
 - Temperature compensation option
 - Optional relay alarm outputs - model SR250D
- 12V model for motor homes available without a cooling fan or switches for operation in ambients < 35°C model SR250K12
 - Designed and manufactured to very high standards to ensure many years of trouble free operation.

SPECIFICATIONS All specifications are typical at nominal input, full load and at 20°C unless otherwise stated.

ELECTRICAL	
Input Voltages	
▪ standard	180V - 264V, 45-65Hz 200 - 375VDC
▪ optional (internal link selectable)	88V - 132V , 45-65Hz 110-180VDC
Fusing / Protection	Internal input fuse
Isolation	3.5KVAC 1 min. in/output 1KV DC input/earth
Efficiency	≥ 85%
Inrush current	Soft start circuit
Output Power	250W continuous (0 - 50°C)
Output Voltages (nominal)	13.8V, 24V, 30V, 36V, 48V Other voltages by request.
Voltage adj. range	85 - 115% of Vout
Temp. Compensation (option)	Temperature sensor on 1.7m lead with adhesive pad: -4mV / °C / cell ±10%
Overcurrent Protection	Constant current limit under overload and short circuit conditions
Line Regulation	<0.2% over AC input range
Load Regulation	<0.4% open circuit to 100% load
Noise	<1%
Drift	0.03% / °C
Hold-up time	15 - 20 mS (nom. - max. Vin) without battery
Thermal Protection	Automatic current reduction if >50°C. Self-resetting
OVP	Over-voltage protection on output at ~ 130% of nominal output voltage

PHYSICAL	
AC Input connector	IEC320 inlet socket (similar to PCs etc.)
DC Connections	M6 brass stud: or 'Phoenix combicon' Plug-in style socket & mating screw terminal block: (max. wire 4mm ² / way)
Enclosure	Powder coated or zinc plated steel / anodised aluminium
*Indication LEDs	Green : DC Power OK, Red : Standby
Weight	1.7 Kg
Alarms (optional)	Plug in screw terminal block. Alarm contacts: C - NO - NC full changeover rated 1A /50V DC, 32VAC

ENVIRONMENTAL	
Operating temperature	0 - 50 °C ambient at full load De-rate linearly >50 °C to no load @ 70 °C
Storage temperature	-10 to 85 °C ambient
Humidity	0 - 95% relative humidity non-condensing
Cooling	Natural convection except for 12V fan cooled. Note: 12V versions for motor homes have no fan for operation at < 35° C ambient
Standby Mode	Turns off DC output of PSU

STANDARDS	
EMI	To CISPR 22 / EN55022 class A
Safety	To IEC950 / EN60950 / AS/NZS3260

ACCESSORIES SUPPLIED	
Mounting Feet together with screws	
AC power cord Standard 1.5m lead with IEC320 socket / local plug	
'Phoenix combicon' DC connector for 'X' version	
Mating screw-terminal plug for alarm outputs	
Crimp lugs for stud terminal versions	

STANDARD PREFERRED MODEL TABLE

MODELS	Output Voltage (factory default)	Output Current (A)	Adjustable range (V)
SR250A12	13.8	18.2 @ 13.8V (20.2 @ 12V)	11-14
SR250A24	24	10.4	22-28
SR250A30	30	8.3	28-36
SR250A36	36	6.9	34-43
SR250A48	48	5.2	45-57

BATTERY CHARGING

Please specify on ordering if unit is for power supply or battery charging duty. The voltage for charging is set at 15% above the nominal voltage:

Model	Volts	Rated Amps
SR250x12	13.8	18.2
SR250x24	27.6	9.1
SR250x36	41.4	6.0
SR250x48	55.2	4.5

MOUNTING DETAILS / DIMENSIONS

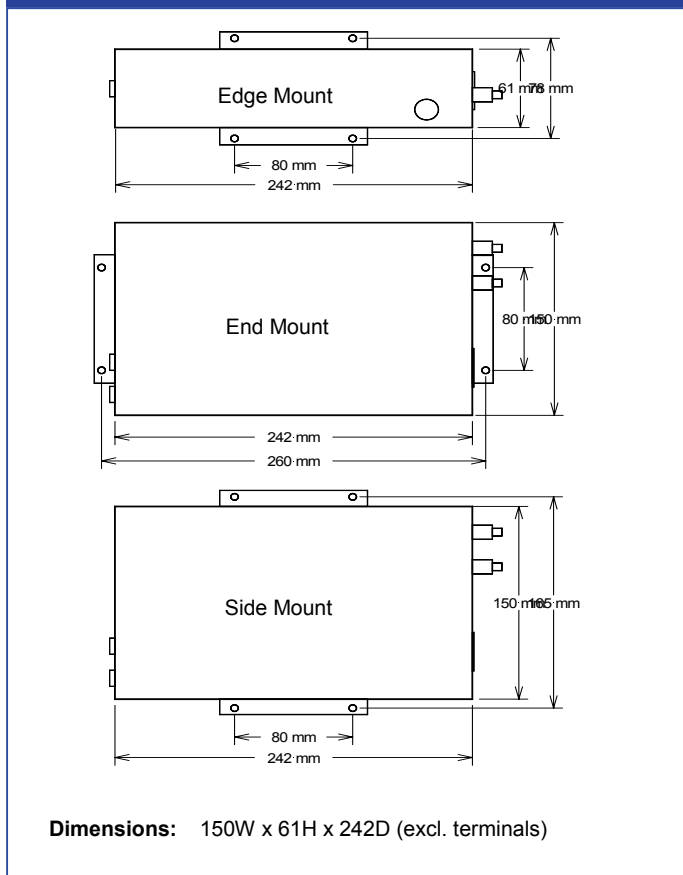

ADDITIONAL OPTIONS

Rack mount	2RU x 19" rack - (rear connection) <i>Refer page 112</i>
Wall Mount Case	Includes two MCBs and terminals - <i>Refer page 114</i>
Distribution Panel	3RU x 19" rack with MCBs - <i>Refer page 113</i>
Temperature Compensation	For accurate battery charging, temperature compensation adjusts voltages in accordance with external temperature probe Order Code: F+TEMPCO
Alarms (SR250D..)	<ul style="list-style-type: none"> • Mains/PSU fail (or PSU in standby-mode) • DC low (Battery low or PSU low) <ul style="list-style-type: none"> - Charger: set at 1.83V/cell (80% Vout) - PSU: set at 83% V out
Earth Fault Alarm	Detects leakage to earth of DC output and provides relay output Order Code: F+EFDLV (24-50V models) F+EFDHV (48-150V models)
Parallel Redundancy or Increase Power (P - type available for 24 & 48V, output diode in PSU case)	Combine two or more 'D' units with output diodes for N+1 redundancy or increased power. <i>Refer page 118 for typical connections</i>
Delete front panel	Available without switches & LED indication
Reverse Polarity Protection (RPP)	For chargers: SR250F... = electronic RPP SR250K... = fused RPP

MODEL CODING AND SELECTION CHART

SR250A 12 T F S L

Input voltage and front panel switches:	230V AC + switch = L 110V AC + switch = U 110V DC + switch = H	230V AC no switch = blank 110V AC no switch = G 110V DC no switch = J
Output DC Connector type:	Stud = S	Phoenix combicon (plug in screw terminal block) = X
Fan cooled:	With fan = F	No fan = blank
Temperature Compensation	Yes = T	No = blank
DC output: Nominal voltage	12, 24, 36, 48	
Function:	A = Standard PSU D = Standard with alarms P = D with output diode for parallel redundancy (24, 48V only) F = Std with electronic RPP, 12 & 24V nom (for use as charger only, not PSU) K = Std with fused RPP, 12 & 24V only (for motor homes)	

PARALLEL REDUNDANCY / SERIAL CONNECTION INFORMATION

Application Solution #1

2 x SR No-Break™ units for increased power output.

This configuration should only be used when there is enough load to prevent one unit from switching off. In lightly loaded situations it is better to use two separate battery strings as shown in Application solution #2.

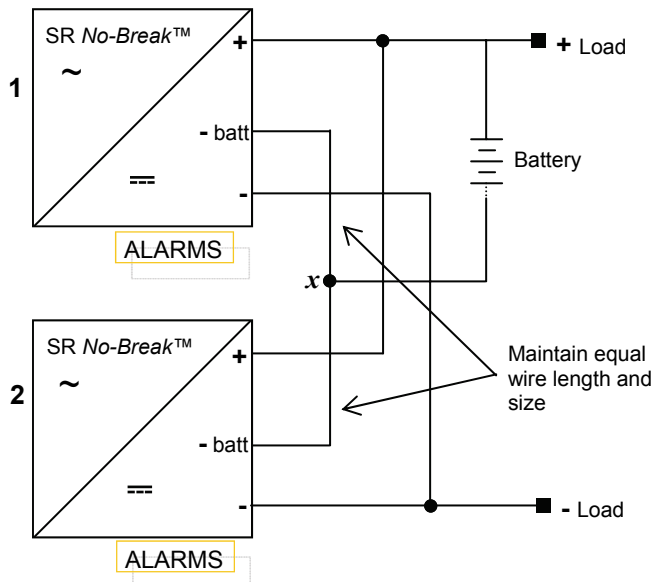

Notes: The wires which common the battery negative lead ('-batt' terminal to common point 'x') **must be** of the same type / gauge and equal in length.

Application Solution #2

2 x SR No-Break™ units and 2 x battery strings connected in parallel for N+1 redundancy (or increased power)

This solution provides an increased level of redundancy with redundancy of the battery in addition to the power supply. The diodes also aid current sharing and isolate the units from one another in the event of a short circuit appearing at the other output.

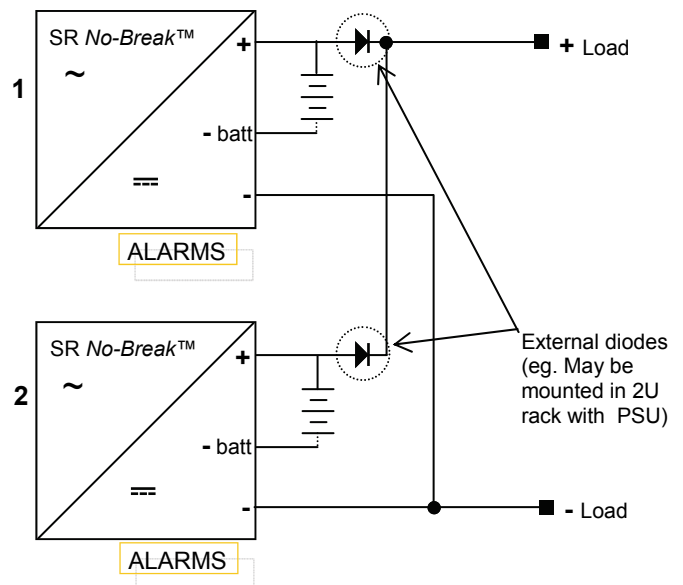

Application Solution #3

Two or more SR xxx D (Standard PSU with alarms) units may be connected in parallel for N+1 redundancy using output diodes. For redundancy, normal practice is to install one additional unit than is necessary to power the load, thus the system is not compromised if one unit fails.

Note that the diodes are mounted external to PSU, except for the SR250D24,36,48 models.

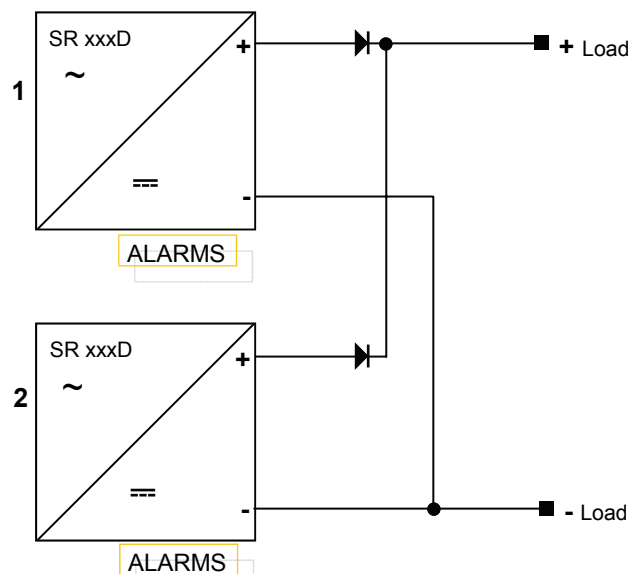

Two or more SR ... A ... units may be connected in parallel for increased power (without diodes). It is essential that the wiring from each unit to the load is kept identical for equal power sharing.

Application Solution #4

Two SR xxx D (Standard PSU with alarms) units series connected for double output voltage

An example of this solution would be the requirement for 100V DC. The preferred solution is to use a specifically designed unit with the desired output, but if urgent or impractical, units can be connected as shown.

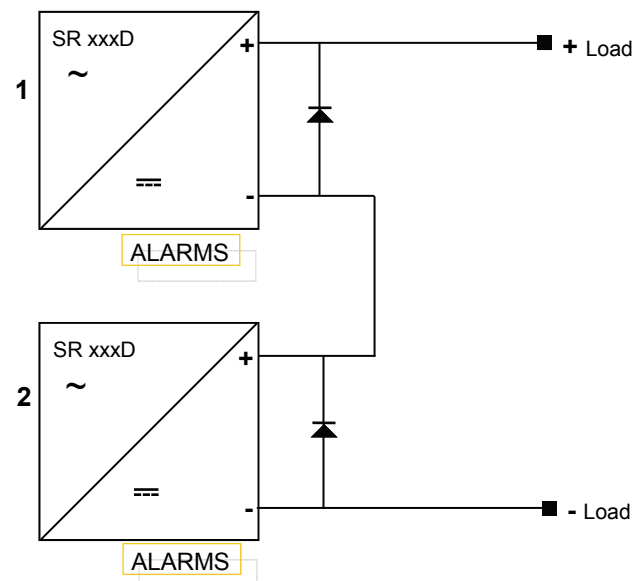

Diodes shown are essential.

CONNECTIONS

If used as a float charger always connect the positive output of the power supply to the positive terminal of the battery. The charger may be permanently connected to float charge lead acid batteries but it is essential to periodically check the electrolyte level of flooded cells as there is always some evaporation.

To minimize the volt drop at the output connections use all the terminals provided ie. Connect output wires in parallel.

CAUTION— SR250K versions

The **SR250K12** has been specially designed for use in motor homes and has no cooling fan for reduced noise levels during operation. **It must not be used when the ambient temperature is above 35 degrees C.**

This model does not have a standby switch or LED indication on the front panel. It has a fuse for reverse polarity protection.

STANDBY FUNCTION

Pushing the **STANDBY** button will turn the output of the PSU off.

LED INDICATION

SR250: **POWER OK** (green) LED off, **STANDBY** (red) LED on
 SR500 &SR500: **POWER OK** (green) LED on, **STANDBY** (red) LED on

OPTIONAL ALARM VERSIONS (SR 250D, SR500D, SR750D or 'P' versions)

Alarm relay de-energized states:

1. No battery connected (operation as PSU only)

Relay 1: Mains fail or PSU in standby mode

Relay 2: DC output low (PSU in current limit or not working), or PSU in standby mode

2. Battery connected (operation as PSU and charger)

Relay 1: Mains fail or PSU in standby mode

Relay 2: Battery voltage is low

Alarm Terminal Configuration

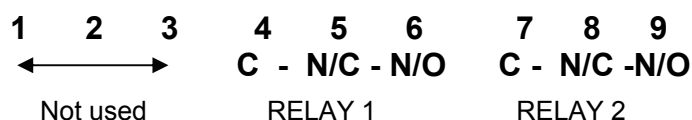

eg. Contact 4-5 will be closed when mains fail occurs

Safety

This equipment is designed to comply with information technology/business equipment standard IEC950.

As stand alone equipment, the design allows for simple connection to mains and output.

The user is responsible for ensuring that input and output wiring segregation complies with local standards and that in the use of the equipment, access is confined to operators and service personnel.

HAZARDOUS VOLTAGES EXIST WITHIN A POWER SUPPLY ENCLOSURE AND ANY REPAIRS MUST BE CARRIED OUT BY A QUALIFIED SERVICEPERSON.

Electrical Isolation Testing

Electric strength tests: Components within the power supply responsible for providing the safety barrier between input and output are constructed to provide electrical isolation as required by the standard. However EMI filtering components could be damaged as result of excessively long high voltage tests between input, output and ground. Please contact our technicians for advice regarding electric strength tests.

Earth Leakage

The internal interference suppression circuit causes earth leakage currents which may be to the maximum allowable of 3.5mA. A low resistance earth connection is essential to ensure safety and additionally, satisfactory interference suppression.

Ventilation

High operating temperature is the cause of the majority of power supply failures. For example a 10°C rise in the operating temperature of a capacitor may halve its expected life. The rated operating temperature of the equipment is the highest test temperature at which internal components will provide maximum lifetime consistent with flexibility in application.

A switchmode power supply with a rated efficiency of 85% at full load draws 1.18 times the output power from the input. This extra power is lost as heat within the circuitry of the unit. Case and heatsinks are designed to provide maximum transfer of heat to the surrounding air. However, if airflow is constrained within a cabinet, a unit will heat its environment and operate at an elevated temperature. The final operating temperature therefore must be considered in the design of a system for maximum trouble free service life.

Batteries housed in the same enclosure as a power supply / charger may also suffer drastically shortened lifetime if subjected to high ambient temperatures - the same life degradation as for capacitors above apply.

Water / Dust

Every effort must be made in the installation to minimise the risk of ingress of water or dust. Dust settling on internal heatsinks will degrade their ability to radiate heat and will also attract moisture, thus possibly causing leakage currents and circuit damage.

Electromagnetic Interference (EMI)

Switching power supplies and DC-DC converters inherently generate electrical noise.

A major aim at the design stage is to suppress switching noise to at least the levels required by the various standards.

Residual noise is nevertheless capable of causing interference in associated equipment if susceptible.

Generally, power supply and susceptible equipment wiring should be well segregated, as short as practicable and all equipment well earthed.

Residual noise can be reduced by looping DC wiring through ferrite cable sleeves. These are most effective as close to the power supply as possible and as many turns of the wire taken through the core (+ and - in the same direction) as the core will accommodate.

For more information, contact our sales office or your distributor.