

# AS-Interface Power Supply with 4A

## SLA4.100

Data sheet

- Input: AC 115V / 230V
- Output: 30.5V / 4A
- AS Interface data decoupling
- Infrared (IR) addressing mode
- Overload protection by FUSE Mode
- For highly demanding industrial applications
- Ground Fault (GF) detector with signal output



AS-Interface  
Appr. No. 41801

CE  
EMC and  
Low Volt.  
Directive

### Short description

#### Data and energy:

The primary switched mode DIN rail power supply SLA4.100 specifically supplies AS Interface® systems with energy. The AS-Interface bus technology allows to connect up to 62 participants to a control and to supply them with energy with a single two-conductor cable. When connecting slaves, the yellow AS-Interface cable offers the high degree of protection IP67 in conjunction with the insulation displacement. The communication signals of the individual network participants are modulated onto the supply voltage. For this purpose, specific power supply units with integrated data decoupling are required for AS-Interface systems.

#### Fast addressing of slaves:

The "IR addressing mode" selectable via jumper interrupts the data communication on the yellow AS-Interface cable. Participants with an infrared interface can then quickly be assigned a new ID address by means of an infrared programming unit without the need to disconnect them from the AS-Interface cable. Afterwards, the "Communication Mode" can be selected again to restart the data communication.

#### Worldwide operation:

This compact primary switched-mode built-in power supply can be operated on all usual single-phase line voltages. Its design corresponds to international standards. The CE-Declaration allows for industrial and office application.

#### Ground fault detector:

Acc. to EN60204 part 1 and DIN VDE0113 respectively, ground faults in control circuits must neither cause a machine to start inadvertently or to dangerously move nor prevent a controlled shutdown. The internal SLA4 ground fault detector makes external ground fault detector modules redundant. The AS-Interface network is monitored by the power supply unit via the AS-Interface cable connected to the various participants. Detected ground faults are stored and signalled via front panel LEDs and relay contacts. The ground fault detector may be manually checked using the test/reset button.

### Input

Rated voltage	AC 100-120/220-240V (selectable by front panel slide switch)			
Rated current	2.7A (switch in 115V position) 1.3A (switch in 230V position)			
Frequency	47...63 Hz (alternatively DC also possible)			
Voltage range	AC 85...132V/184...264V, DC 240...300V			
Harmonic current emissions	EN 61000-3-2 [PFC], Class A limits are fulfilled			
Integrated internal fuse	T3A15/250V HBC (not accessible)			
Inrush current	limited by NTC resistor T <sub>amb</sub> = +50°C, cold start (line impedance acc. EN 61000-3-3)			
Peak current I <sub>pk</sub>	AC 120V	AC 132V	AC 230V	AC 264V
I <sub>t</sub> <sup>2</sup>	<44.7A	<49.3A	<49.7A	<57.5A
Hold-up time	>30ms @ AC 100V or 196V and rated load (also see diagram)			

### Output

Rated voltage	DC 30.5V ±3% (not adjustable)		
Rated current	4.0A		
Isolation	Safe low voltage	PELV (IEC 60364-4-41) SELV (IEC 60950)	
Current limitation	>4.2 A		
Overload behaviour	Continuous current (also see diagram)		
Short-circuit current	>4.2A, <6.5A		
Load regulation	stat. <250mV (no load / full load)		
Line regulation	stat. <10mV (AC 85...132V/184...264V)		
Ripple	<50 mV <sub>pp</sub> (500kHz bandw., 50Ω measurem., ohmic load)		
Noise (Spikes)	<150mV <sub>pp</sub> (20MHz bandw., 50Ω measurem., ohmic load)		
Over-voltage protection	max. 55V		
Operating indicator	Green LED (extinguishes at overload)		
Output is protected against short-circuit, open circuit and overload.			
Use AS-Interface power supplies only together with AS-Interface lines.			

### Order information

Order number	Description
SLA4.100	AS-Interface power supply unit
SLZ13	Adapter for S7-300 rail
SLZ02	Wall mounting set (two pcs. per package)

### Ground fault detector

The ground fault detector monitors ground faults on the AS-Interface lines and includes a self-test feature. The ground fault feature consists of the LED 'Ground Fault (GF)', a 'Test/Reset' push-button and a relay output. In case of failure, the output voltage will not switch off. For proper functioning, it is essential to connect the shield terminal to PE or machine ground. The AS-Interface network must not contain any other ground fault detectors or insulation monitoring devices.

LED 'Ground Fault (GF)' displays a current or stored ground fault push-button 'Reset/test'

- push <2s to start test function
- push >2s to reset stored ground fault

Ground fault relay normally closed contact (NC); opens in the event of ground fault

- max.  $V_{switch}$  AC 25V or DC 60V
- max.  $I_{switch}$  0.5A

### Operating and environmental data

Non-operating temperature range	-25°C...+85°C
Operating temperature range	-10°C...+70°C (measured at 25mm below the unit)
Derating	from 60°C 3W/K onwards, power reduction necessary (see diagram)
Cooling	natural convection, no forced air-cooling necessary
Over-temperature protection	not implemented
Humidity	protect from moisture and condensation
Vibration	2 – 17.8Hz ±1.6mm (IEC 68-2-6)
• Sinus	17.8Hz – 500Hz 2g (IEC 68-2-6)
• Random	2...800Hz 0.5m <sup>2</sup> (s <sup>3</sup> ) (IEC 68-2-64)
Shock	15g (6ms), 10g (11ms), IEC 68-2-27
Degree of pollution	2 (EN 60950)
Overvoltage category	II (IEC 60950; IEC 60664), III (EN 50178)

### Electromagnetic Compatibility (EMC)

Emissions	EN 61000-6-3 (also includes EN 61000-6-4) Class B (EN 55011, EN 55022) EN 61000-3-2 (A14) and EN 61000-3-3
Immunity	EN 61000-6-2 (also includes EN 61000-6-1), EN 61000-4-2, Level 4 (withstands 8 kV direct discharge, 15 kV air discharge)
• Electrostatic Discharge (ESD)	
• Electromagnetic radiated fields	EN 61000-4-3, Level 3 (10 V/m) ENV 50204 (10 V/m)
• Burst, coupled to:	EN 61000-4-4, Level 4 (4 kV)
– ACin lines	Level 3 (2 kV)
– DCout lines	Level 3 (1 kV)
– Signal lines	
• Surge transients	EN 61000-4-5, Installation class 4 (4 kV)
– Differential mode (L→PE, N→PE)	
– Common mode (L → N)	Installation class 4 (2 kV)
• Conducted noise immunity	EN 61000-4-6, Level 3 (10V, 150 kHz-80 MHz)
• Voltage dips	EN 61000-4-11
• Transient immunity	Transient resistance acc. to VDE 0160 / W2 over entire load range

### Efficiency, Reliability

Efficiency	typ. 90%	(AC 230V, 4A)
Power dissipation	typ. 13.5W	(AC 230V, 4A)

### Schematic

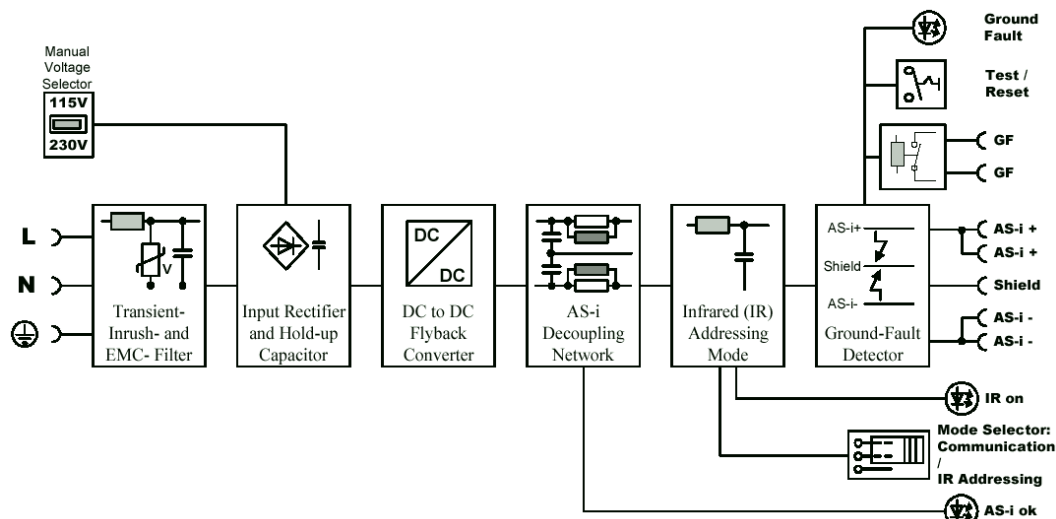

Operating indicators and elements

Plastic slider:

- Mounting: Place the unit onto the DIN-rail and push it downwards and against the lower front edge until it snaps into place.
- Detachment: Push downwards and detach the unit from its DIN-rail mounting bracket.

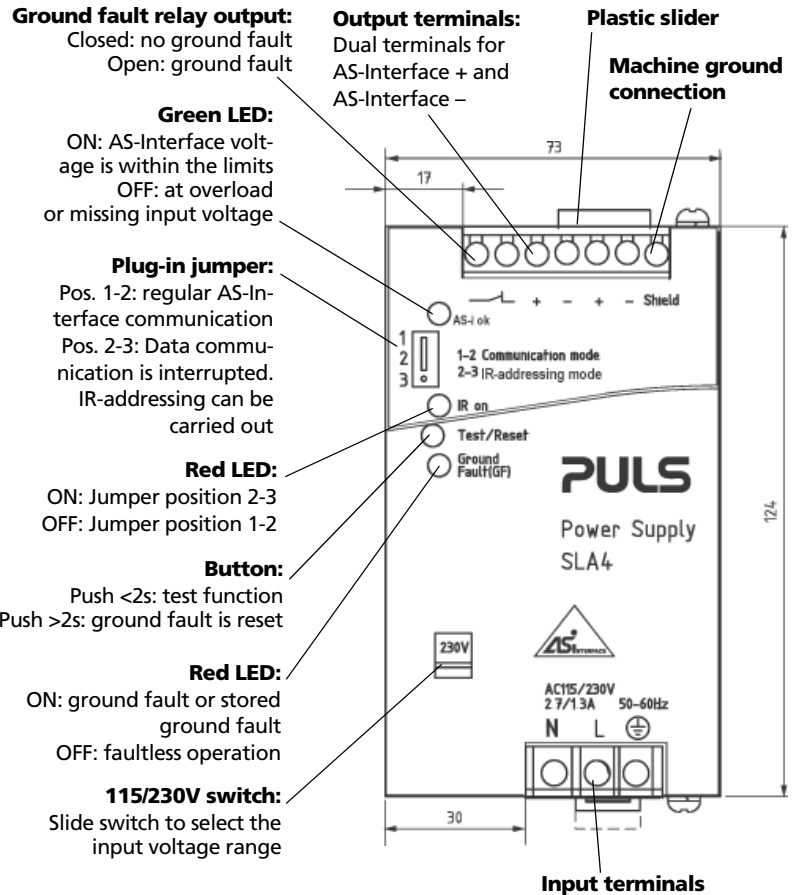
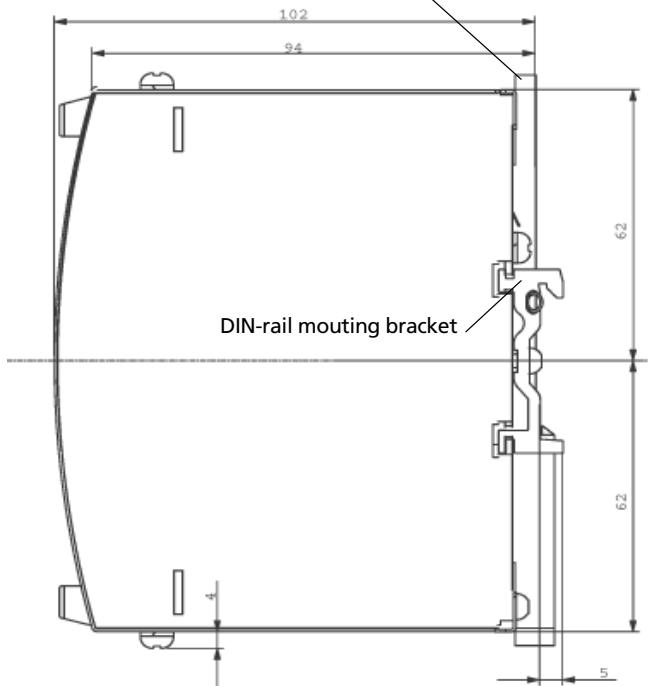

Connectors and terminals

Terminals	Fingertouch-proof terminals with captive screws for 5.5mm slotted screwdriver or Philips cross-recessed screwdriver No. 2
Position	Easy to reach terminals on the front panel; input and output clearly separate from each other
Tightening torque	0.8Nm
Wire gauge	
• flexible cable	0.5-4mm <sup>2</sup> (20-10AWG)
• solid cable	0.5-6mm <sup>2</sup> (20-10AWG)
Ferrules	admissible
Stripping length	7mm

Front elements

⊕	PE terminal
N	Input neutral
L	Input phase
GF ok	Ground Fault (GF) output (twice); normally closed contact relay type, signals ground fault
⊕ brown	Positive AS-Interface output voltage (twice)
⊖ blue	Negative AS-Interface output voltage (twice)
Shield	Connection of machine ground (Functional earth for balancing the AS-Interface output. Connection is recommended for EMC)

Construction / Mechanics

Housing	Robust metal housing for built-in installation
Degree of protection	IP20 (EN 60529)
Class of protection	1 (IEC 60536); do not use without protective earth (PE)
Width w	73 mm
Height h	124 mm
Depth d	102 mm (without DIN rail)
Weight	650g

Installation notes

External fusing	<ul style="list-style-type: none"> <li>• not necessary (internal fuse)</li> <li>• observe national regulations</li> <li>• circuit breaker with B-characteristic min. 6A or slower action, or alternatively 6A HBC fuse</li> </ul>
Mounting position	vertical; input below, output above
Free space for cooling	above / below 25mm recommended left / right 15mm recommended

Always connect PE before operating the unit!

**Operation without AS-Interface:** This AS-Interface PSU has an inductive output. When operating without AS-Interface structure (e.g. in a laboratory test) you should connect a 470µF / 35V capacitor between AS-Interface + and AS-Interface – as commercial electronic loads in combination with the data decoupling often tend to oscillate, and the oscillation may exceed the permitted modulation voltage. Otherwise, equipment may be destroyed.

Functional diagrams

Start behaviour

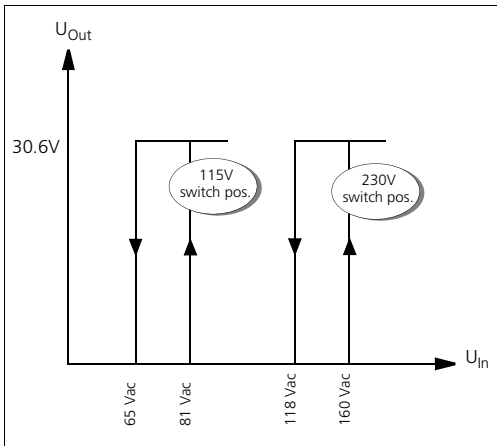

Hold-up time

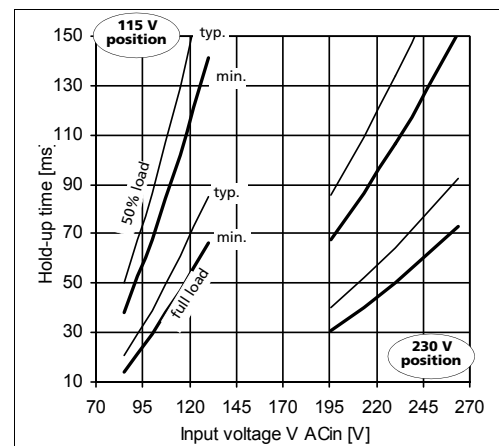

Efficiency / Power dissipation

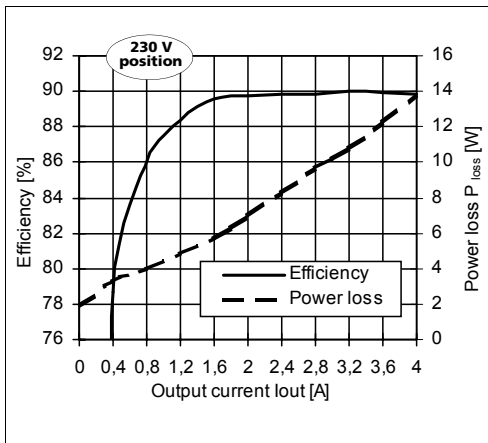

Output characteristic / Overload behaviour

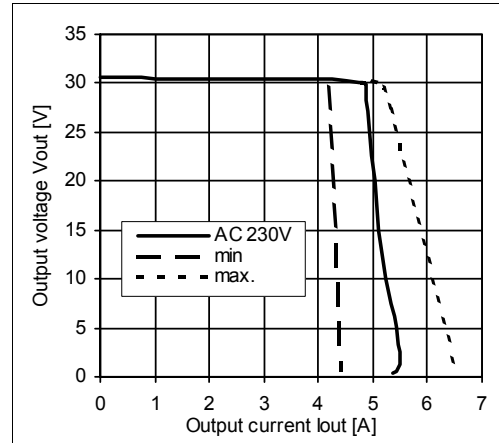

Insulation diagram

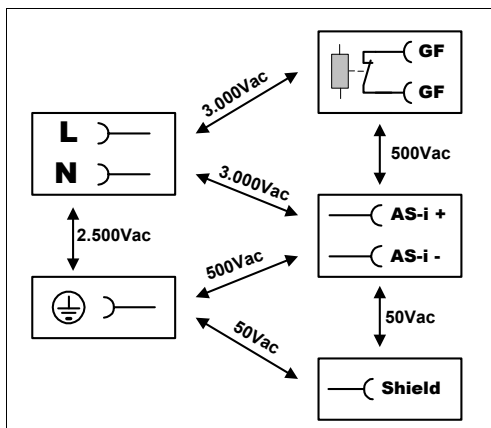

Derating

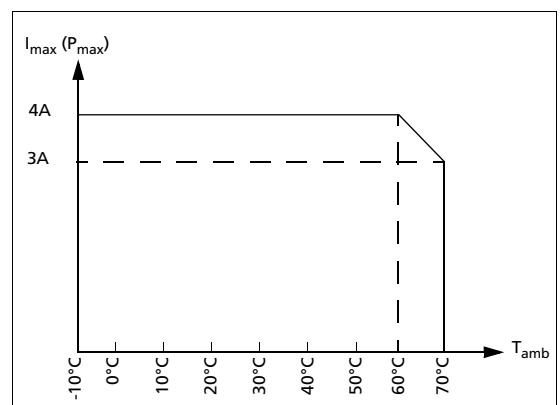

Unless otherwise stated, specifications are valid for AC 230V input voltage, +25°C ambient temperature, and 5 min. run-in time. They are subject to change without prior notice.

Your partner in power supply:



Bayerns Best 50  
Czech 100 Best  
Europe's 500

PULS GmbH

Arabellastraße 15  
D-81925 München  
Tel.: +49 89 9278-0  
Fax: +49 89 9278-199  
www.puls-power.com