



REDUNDANCY MODULE

- Dual input, single output
- Alarm relay-contacts for each input path
- Rugged metal housing
- Width only 32mm
- Cost effective solution to build redundant systems
- 24-60V Wide-range input
- 20A Continuous output current
- Easy wiring; Distribution terminals for negative pole included
- Large screw terminals
- 3 Year warranty

1. GENERAL DESCRIPTION

The YRM2.DIODE is a redundancy module, which can be used for various purposes. The most popular application is to configure a highly reliable and true redundant power supply systems. This redundancy module has a monitoring circuitry included. Two LEDs and two relay contacts signal when one of the two DC-input voltages is not in range due to a non-functioning or disconnected power supply.

Another interesting application is the separation of sensitive loads from non-sensitive loads. This avoids the distortion of the power quality for the sensitive loads which can cause controller failures.

Alongside with the YRM2.DIODE, there exists the decoupling module YR2.DIODE which has no monitoring circuitry included. This is the perfect fit when the power supply itself is already equipped with a DC-OK signal (e.g.: DIMENSION Q-Series).

2. SHORT-FORM DATA

Input voltage	DC 24V	
Input voltage range	24-60Vdc	
Input current	2x 12.5A	1+1 Redundancy
	2x 10A	N+1 Redundancy
	1x 20A	Single use
Output current	max. 20A	Normal mode
	max. 25A	Overload / short-circuit
Input to output voltage drop	typ. 0.85V	At 20A output current
Alarm threshold	typ. 21.5V	LED and relay contact for each input
Power losses	1 W	At no load
	18W	At 20A output current
Temperature range	-25°C to +70°C	Operational
Derating	0.5A/°C	+60 to +70°C
Dimensions	32x124x117mm	WxHxD

3. ORDER NUMBERS

Redundancy Module	YRM2.DIODE	Dual input / single output
Accessory	ZM1.WALL	Wall / panel mount bracket
	ZM11.SIDE	Side mount bracket

4. MARKINGS



Marine, pending

INDEX PAGE

1. General Description	1
2. Short-form Data	1
3. Order Numbers	1
4. Markings	1
5. Input and Output Characteristics	3
6. Power Losses	4
7. Alarm Contacts	4
8. Functional Diagram	5
9. Front Side and User Elements	5
10. Terminals and Wiring	6
11. Reliability	6
12. EMC	7
13. Environment	8
14. Protection Features	9
15. Safety	9
16. Dielectric Strength	9

INDEX PAGE

17. Approvals	10
18. Fulfilled Standards	10
19. Used Substances	10
20. Physical Dimensions and Weight	11
21. Installation and Operation Instructions	11
22. Accessory	12
23. Application Notes	13
23.1. Recommendations for Redundancy	13
23.2. 1+1 Redundancy up to 10A	13
23.3. 1+1 Redundancy up to 20A	14
23.4. N+1 Redundancy, Example with 20A	14
23.5. Battery Back-up	15
23.6. Redundancy for Sensitive Loads	15
23.7. Decoupling of Buffered Branches	16
23.8. Use in a Tightly Sealed Enclosure	16
23.9. Mounting Orientations	17

INTENDED USE

The redundancy module shall only be installed and put into operation by qualified personnel.

This redundancy module is designed for installation in an enclosure and is intended for the general use, such as in industrial control, office, communication, and instrumentation equipment. Do not use this device in aircraft, trains and nuclear equipment, where malfunctioning of the power supply may cause severe personal injury or threaten human life.

TERMINOLOGY AND ABBREVIATIONS

PE and \oplus symbol	PE is the abbreviation for P rotective E arth and has the same meaning as the symbol \oplus .
Earth, Ground	This document uses the term "earth" which is the same as the U.S. term "ground".
T.b.d.	To be defined, value or description will follow later.
DC 24V	A figure displayed with the AC or DC before the value represents a nominal voltage with standard tolerances (usually $\pm 20\%$) included. E.g.: DC 12V describes a 12V battery disregarding whether it is full (13.7V) or flat (10V)
24Vac	A figure with the unit (Vac) at the end is a momentary figure without any additional tolerances included.

DISCLAIMER

The information presented in this document is believed to be accurate and reliable and may change without notice.

5. INPUT AND OUTPUT CHARACTERISTICS

Number of inputs	nom.	2	
Number of outputs	nom.	1	
Input voltage	nom.	DC 24V	
Input voltage range	-	22-60Vdc	
Voltage drop, input to output	typ.	0.85V	At 2x10A, see Fig. 5-1
Input current	max.	2x 12.5A	Continuous, 1+1 Redundancy, see Fig. 5-2
	max.	2x 10A	Continuous, N+1 Redundancy, see Fig. 5-3
	max.	1x 20A	Continuous, Single use, see Fig. 5-4
Input current	max.	2x 18.5A	Up to 5s, 1+1 Redundancy, continuous, see Fig. 5-2
	max.	2x 15A	Up to 5s, N+1 Redundancy, continuous, see Fig. 5-3
	max.	1x 30A	Up to 5s, Single use, continuous, see Fig. 5-4
Peak input current	max.	150A	Max. 10ms, per input
Output current	max.	20A / 30A	Normal mode, continuous / up to 5s
	max.	25A / 37.5A	At overload or short-circuit, continuous / up to 5s
Reverse current	max.	2mA	Per input, -25°C to +60°C
Reverse voltage	max.	200Vdc	Voltage applied to the output, continuously allowed

Note: Ensure that the continuous output current does not exceed 25A. Check the short-circuit current of the power sources and if the power source can deliver more than 25A, use an appropriate fuse on the output.

Fig. 5-1 **Voltage Drop**

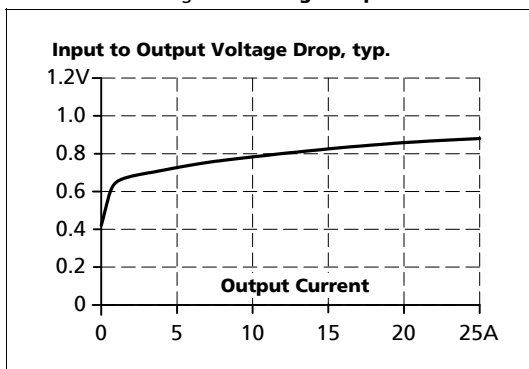

Fig. 5-2 **1+1 Redundancy**

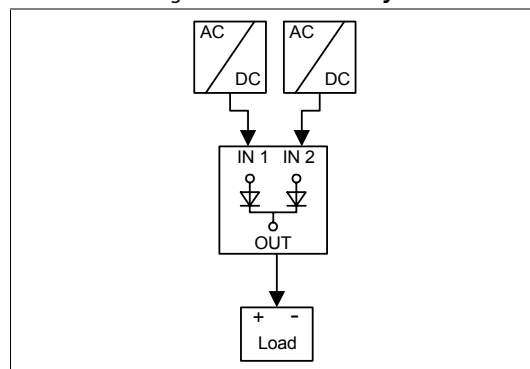

Fig. 5-3 **N+1 Redundancy**

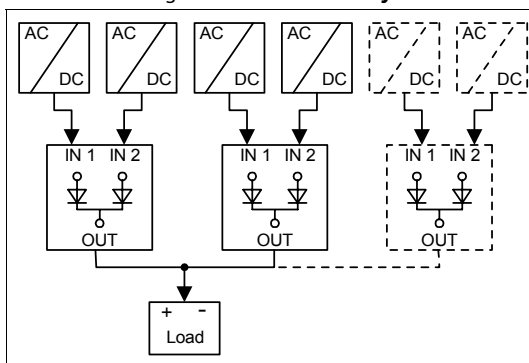
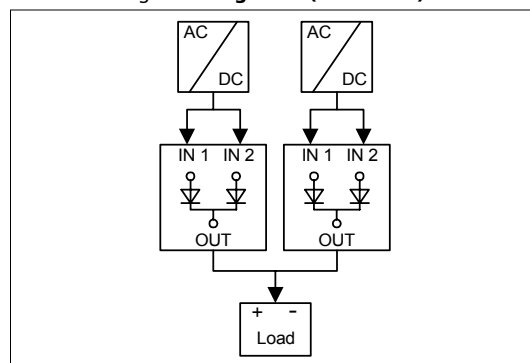

Fig. 5-4 **Single use (redundant)**



6. POWER LOSSES

Power losses	typ.	1.0W	10-60Vdc, 0A output current, see Fig. 6-1
		4.6W	10-60Vdc, 5A output current, see Fig. 6-1
	typ.	8.85W	10-60Vdc, 10A output current, see Fig. 6-1
	typ.	18.0W	10-60Vdc, 20A output current, see Fig. 6-1

Fig. 6-1 Power losses vs. output current

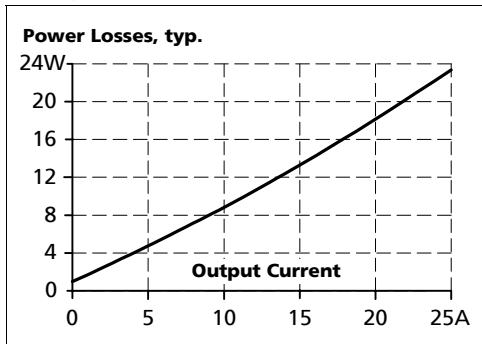

7. ALARM CONTACTS

Both input voltages are monitored individually. If one input voltage is too low or completely lost, it will be indicated by an alarm relay contact.

Each input has his own monitoring circuitry and relay contact.

Alarm threshold	nom.	21.5V (±0.5V)	Relay contact opens immediately after the input voltage falls below this value.
Contact ratings	max	60Vdc 0.3A, 30Vdc 1A, 30Vac 0.5A	Resistive load
	min	1mA at 5Vdc	Min. permissible load
Isolation voltage	See dielectric strength table in section 16		

8. FUNCTIONAL DIAGRAM

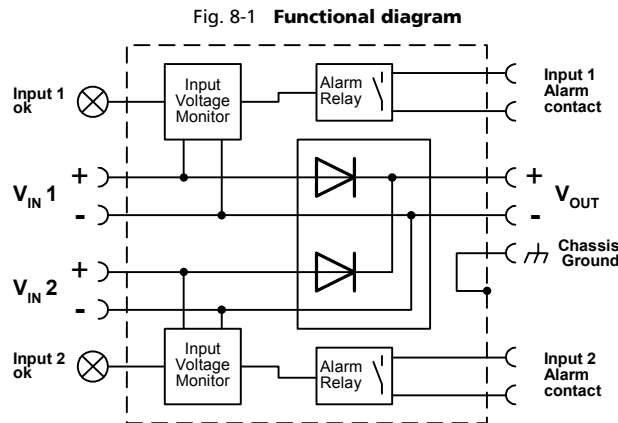

9. FRONT SIDE AND USER ELEMENTS

Fig. 9-1 Front side

Alarm-contacts (relays)

plug connector
(NO-contact)

11, 12 Alarm-contact for input 1

13, 14 Alarm-contact for input 2

Input Terminals

Screw terminals

+ Positive input

- Negative (return) input

Output Terminals

N ... Neutral input

L ... Line (hot) input

⊕ ... PE (Protective Earth) input



DC-ok lamp (green)

The LEDs report a correct input voltage.
Fixed threshold: 21.5Vdc

The LED is ON if the corresponding input voltage is above the threshold level.

The Input-ok LEDs and the alarm-contacts function synchronized.

See chapter 10 "Terminals and Wiring" to choose appropriate wire gauges

10. TERMINALS AND WIRING

Type Screw terminals, Alarm-signal terminals are pluggable
IP20 Finger safe construction. Suitable for field- and factory installation.

Ferrules allowed, but not required

	Input and output terminals	Alarm-signal terminals
Solid wire	0.5-6mm ²	0.2-1.5mm ²
Stranded wire	0.5-4mm ²	0.2-1.5mm ²
American wire gauge	20-10 AWG	22-14 AWG
Wire stripping length	10mm / 0.4inch	6mm / 0.25inch
Recommended tightening torque	0.8Nm / 7lb.in	0.4Nm / 3.5lb.in

Instructions for wiring:

- a) Use appropriate copper cables that are designed for an operating temperature of:
60°C for ambient up to 45°C and
75°C for ambient up to 60°C minimum.
- b) Follow national installation codes and installation regulations!
- c) Ensure that all strands of a stranded wire enter the terminal connection!
- d) Up to two stranded wires with the same cross section are permitted in one connection point (except PE wire).
- e) Do not use the unit without PE connection.

11. RELIABILITY

DC 24V			
Lifetime expectancy	min.	> 25 years	40°C, input: 2x10A, output: 20A, no electrolytic capacitors involved
	min.	> 25 years	40°C, input: 2x5A, output: 10A, no electrolytic capacitors involved
	min.	> 25 years	25°C, input: 2x10A, output: 20A, no electrolytic capacitors involved
MTBF SN 29500, IEC 61709		T.B.D.	40°C, input: 2x10A, output: 20A
		T.B.D.	25°C, input: 2x10A, output: 20A
MTBF MIL HDBK 217F		T.B.D.	40°C, input: 2x10A, output: 20A, Ground Benign GB40
		T.B.D.	25°C, input: 2x10A, output: 20A, Ground Benign GB25

The **Lifetime expectancy** shown in the table indicates the operating hours (service life) and is determined by the lifetime expectancy of the built-in electrolytic capacitors.

Lifetime expectancy is specified in operational hours. Lifetime expectancy is calculated according to the capacitor's manufacturer specification. The prediction model allows a calculation of up to 15 years from date of shipment.

MTBF stands for **Mean Time Between Failure**, which is calculated according to statistical device failures, and indicates reliability of a device. It is the statistical representation of the likelihood of the unit to fail and does not necessarily represent the life of a product.

12. EMC

The redundancy module is suitable for applications in industrial environment as well as in residential, commercial and light industry environment without any restrictions. CE mark is in conformance with EMC guideline 89/336/EEC and 93/68/EEC and the low-voltage directive (LVD) 73/23/EWG. A detailed EMC Report is available upon request

EMC Immunity	EN 61000-6-1 EN 61000-6-2	Generic standards		
Electrostatic discharge	EN 61000-4-2	Contact discharge	8kV	Criterion A
		Air discharge	15kV	Criterion A
Electromagnetic RF field	EN 61000-4-3	80MHz-1GHz	10V/m	Criterion A
Fast transients (Burst)	EN 61000-4-4	Input	2kV	Criterion A
		Output	2kV	Criterion A
		Alarm contacts	2kV	Criterion A
Conducted disturbance	EN 61000-4-6	0.15-80MHz	10V	Criterion A

Criteria:

A: Device shows normal operation behavior within the defined limits.

EMC Emission	EN 61000-6-3 and EN 61000-6-4	Generic standards	
Conducted emission	EN 55011, EN 55022, FCC Part 15, CISPR 11, CISPR 22	Class B, input lines	
	EN 55022	Class B, output lines	
Radiated emission	EN 55011, EN 55022	Class B	

This device complies with FCC Part 15 rules.

Operation is subjected to following two conditions: (1) this device may not cause harmful interference, and (2) this device must accept any interference received, including interference that may cause undesired operation.

13. ENVIRONMENT

Operational temperature	-25°C to +70°C (-13°F to 158°F)	Reduce output power above +60°C
Output de-rating	0.5A/°C	60-70°C (140°F to 158°F), see Fig. 13-1
Storage temperature	-40°C to +85°C (-40°F to 185°F)	Storage and transportation
Humidity	5 to 95% r.H.	IEC 60068-2-30 Do not energize while condensation is present
Vibration sinusoidal	2-17.8Hz: ±1.6mm; 17.8-500Hz: 2g 2 hours / axis	IEC 60068-2-6
Vibration random	0.5m ² (s ³) 2 hours / axis	IEC 60068-2-64
Shock	30g 6ms, 20g 11ms 3 bumps / direction, 18 bumps in total	IEC 60068-2-27
Altitude	0 to 6000m (0 to 20 000ft)	Reduce output power or ambient temperature above 2000m sea level.
Output de-rating (for altitude)	1.25A/1000m or 5°C/1000m	Above 2000m (6500ft), see Fig. 13-2
Over-voltage category	III	EN 50178, (for clearance and creepage distances)
Degree of pollution	2	EN 50178, not conductive

Fig. 13-1 **Output current vs. ambient temp.,**

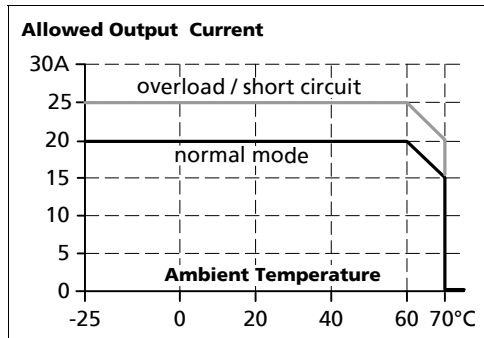
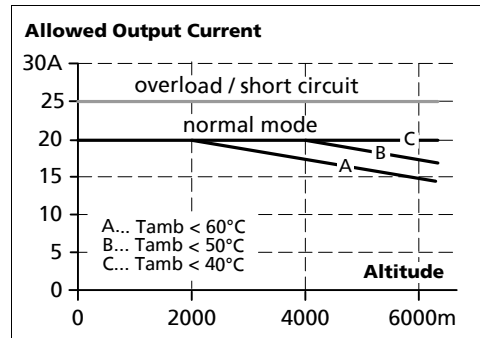

Fig. 13-2 **Output current vs. altitude**



The ambient temperature is defined as the air temperature 2cm below the unit.

14. PROTECTION FEATURES

Output over-current protection	not included	
Degree of protection	IP 20	EN/IEC 60529
Penetration protection	> 3.5mm	E.g. screws, small parts
Over-temperature protection	no	
Input transient protection	no	
Internal input fuse	not included	

Note: In case of a protection event, audible noise may occur.

15. SAFETY

Input / output separation	200V Epitaxial diode	
Class of protection	III	PE (Protective Earth) connection not mandatory
PE resistance	< 0.10hm	Between housing and PE terminal

16. DIELECTRIC STRENGTH

Fig. 16-1 Dielectric strength

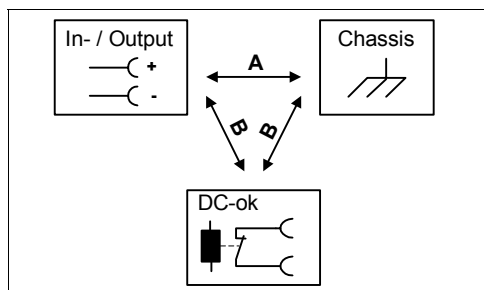

		A	B
Type test	60s	500Vac	500Vac
Factory test	5s	500Vac	500Vac
Field test	5s	500Vac	500Vac

Type tests and factory tests:

Conducted by the manufacturer. Do not repeat test in field!

Rules for field test:

Use appropriate test equipment which applies the voltage with a slow ramp!

During testing, connect all output and input poles together.

The input and output voltage is floating and has no ohmic connection to ground.

17. APPROVALS

UL 508
pending



LISTED E198865 listed for use in U.S.A.
UL 508 Industrial Control Equipment

UL 60950-1
pending



RECOGNIZED E137006 recognized for the use in U.S.A. (UL 60950-1) and Canada (C22.2 No. 60950)
Information Technology Equipment

Marine
pending



GL (Germanischer Lloyd) classified and ABS (American Bureau for Shipping) PDA for marine and offshore applications.
Environmental category: C, EMC2

18. FULFILLED STANDARDS

EN/IEC 60204-1 Safety of Electrical Equipment of Machines

EN/IEC 61131-2 Programmable Controllers

EN 50178 Electronic Equipment in Power Installations

19. USED SUBSTANCES

The unit does not release any silicone and is suitable for the use in paint shops.

Electrolytic capacitors included in this unit do not use electrolytes such as Quaternary Ammonium Salt Systems.

Plastic housings and other molded plastic materials are free of halogens, wires and cables are not PVC insulated.

The production material within our production does not include following toxic chemicals:

Polychlorized Biphenyl (PCB), Polychlorized Terphenyl (PCT), Pentachlorophenol (PCP), Polychlorinated naphthalene (PCN), Polybrom Biphenyl (PBB), Polybrom Bipheny-oxyd (PBO), Polybrominated Diphenylether (PBDE), Polychlorinated Diphenylether (PCDE), Polydibromphenyl Oxyd (PBDO), Cadmium, Asbest, Mercury, Silicia

20. PHYSICAL DIMENSIONS AND WEIGHT

Weight	350g / 0.77lb
DIN-Rail	Use 35mm DIN-rails according to EN 60715 or EN 50022 with a height of 7.5 or 15mm. The DIN-rail height must be added to the depth (117mm) to calculate the total required installation depth.
Electronic files with mechanical data can be downloaded at www.pulspower.com	

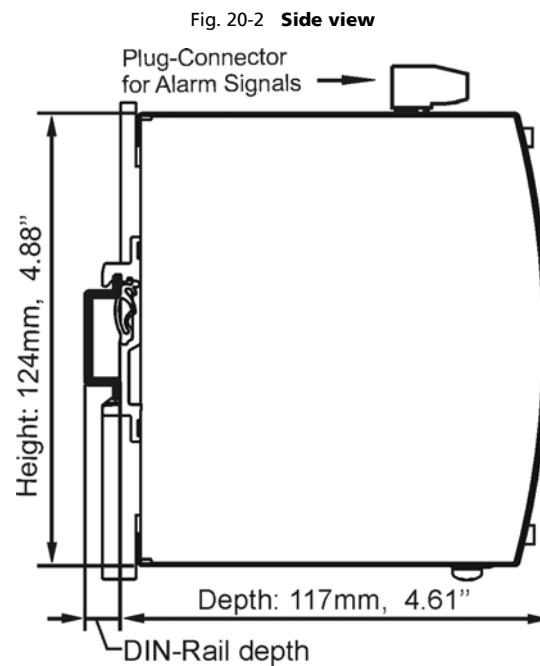
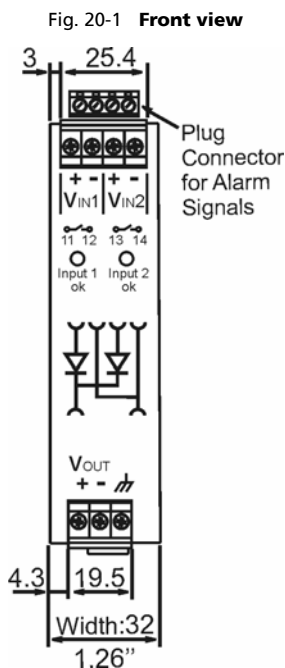

21. INSTALLATION AND OPERATION INSTRUCTIONS

Mounting Orientation:

Input terminal must be located on top and output terminal on the bottom. For other orientations see section 0

Cooling:

Convection cooled, no forced cooling required. Do not cover ventilation grid (e.g. cable conduits) by more than 30%!

Installation clearances:

40mm on top, 20mm on the bottom, 5mm on the left and right side are recommended when loaded permanently with full power. In case the adjacent device is a heat source, 15mm clearance is recommended.

Risk of electrical shock, fire, personal injury or death!

Turn power off before working on the module. Protect against inadvertent re-powering.

Make sure the wiring is correct by following all local and national codes.

Do not open, modify or repair the unit.

Use caution to prevent any foreign objects from entering into the housing.

Do not use in wet locations or in areas where moisture or condensation can be expected.

Service parts:

The unit does not contain any serviceable parts.

22. ACCESSORY

ZM1.WALL Wall mounting bracket

This bracket is used to mount Dimension units onto a flat surface without utilizing a DIN-Rail. The two aluminum brackets and the black plastic slider of the unit have to be detached, so that the two steel brackets can be mounted.

Fig. 22-1 **ZM1.WALL Wall Mounting Bracket**

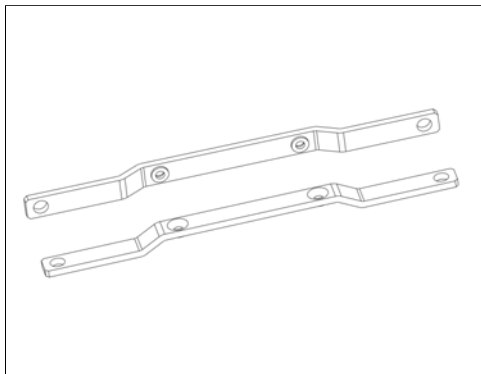
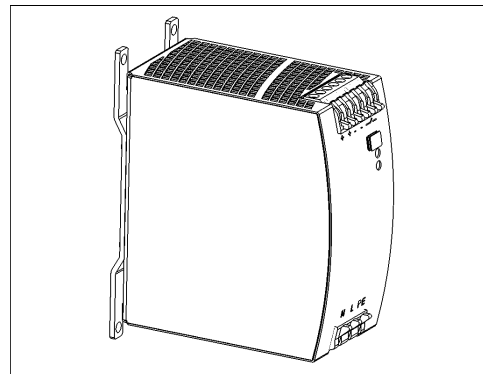

Fig. 22-2 **Assembled Wall Mounting Bracket**



ZM11.SIDE Side mounting bracket

This bracket is used to mount Dimension units sideways with or without utilizing a DIN-Rail. The two aluminum brackets and the black plastic slider of the unit have to be detached, so that the steel brackets can be mounted.

For sideways DIN-rail mounting, the removed aluminum brackets and the black plastic slider need to be mounted on the steel bracket.

Fig. 22-3 **ZM11.SIDE Side Mounting Bracket**
(Picture shows a mounted QS10 power supply)

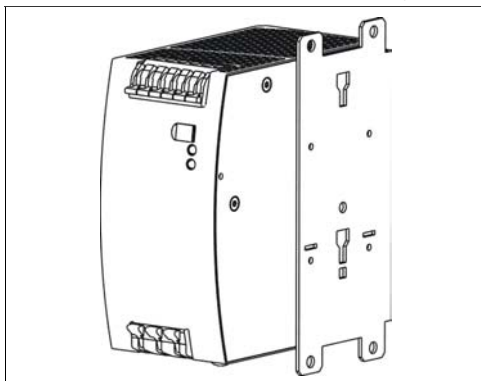
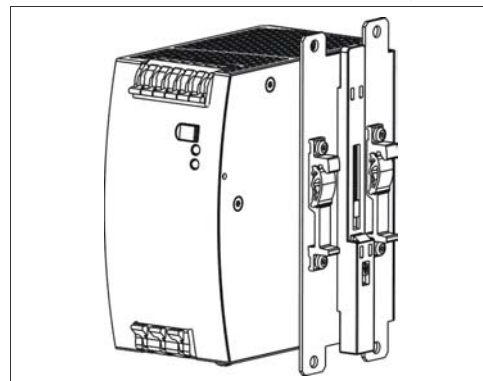

Fig. 22-4 **Side Mounting with DIN-rail brackets**
(Picture shows a mounted QS10 power supply)



23. APPLICATION NOTES

23.1. RECOMMENDATIONS FOR REDUNDANCY

Recommendations for the configuration of redundant power systems:

- Use separate input fuse for each power supply.
- Use Three-phase power supplies to gain functional safety if one phase fails.
- When Single-phase power supplies are utilized connect them to different phases or mains circuits.
- Use both inputs in parallel for currents above 10A.

23.2. 1+1 REDUNDANCY UP TO 10A

1+1 Redundancy up to 10A requires two 10A power supplies and one YRM2.DIODE redundancy module.

Fig. 23-1 **Wiring diagram, 1+1 Redundancy, 10A output current**

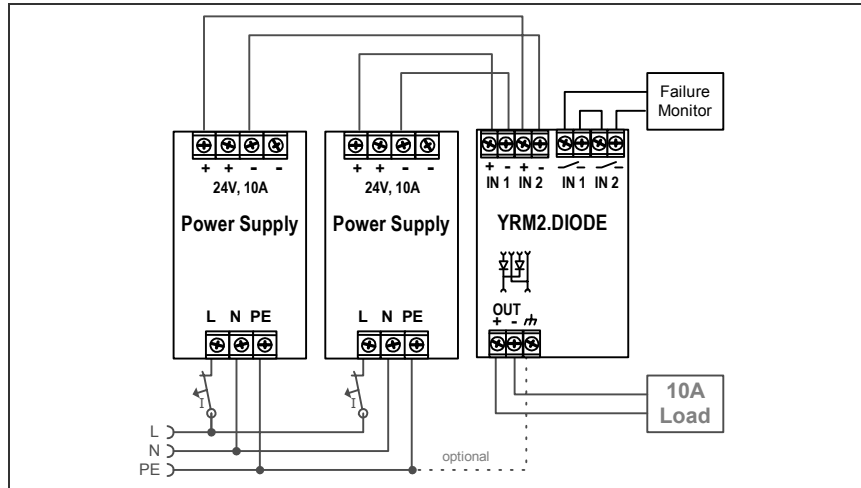

23.3. 1+1 REDUNDANCY UP TO 20A

1+1 Redundancy up to 20A requires two 20A power supplies and two YRM2.DIODE redundancy modules.

Fig. 23-2 **Wiring diagram, 1+1 Redundancy, 20A output current**

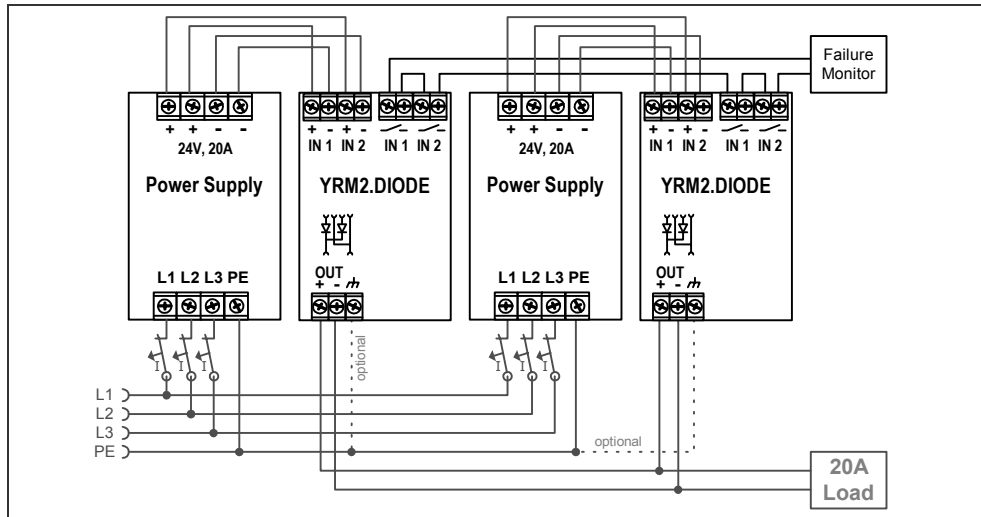

23.4. N+1 REDUNDANCY, EXAMPLE WITH 20A

N+1 Redundancy with 20A requires three 10A power supplies and two YRM2.DIODE redundancy modules.

Fig. 23-3 **Wiring diagram, N+1 Redundancy, example with 20A load current**

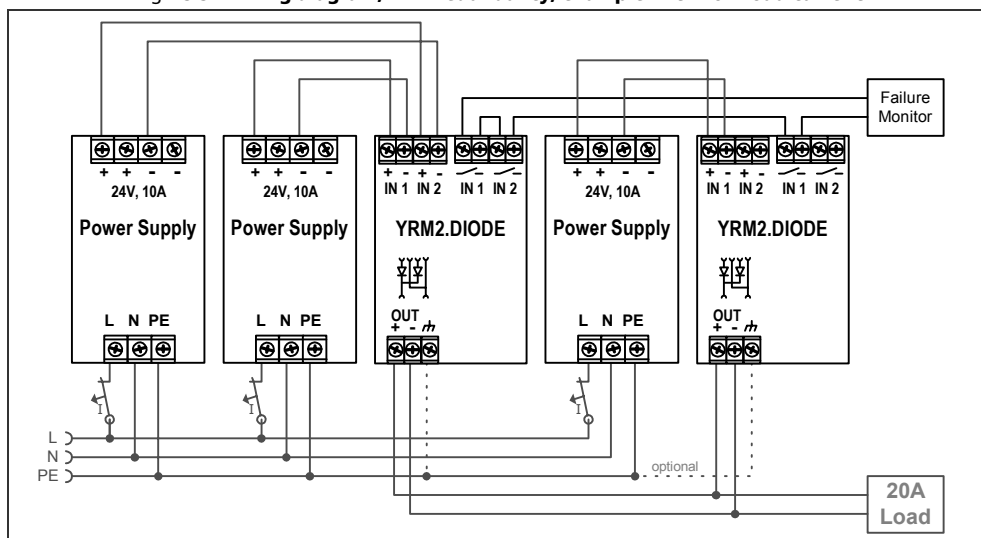

23.5. BATTERY BACK-UP

A battery back-up with 10A requires one 10A power supply and one YRM2.DIODE redundancy module.

Please note:

Set output voltage of power supply to 26.5Vdc minimum to avoid that the charger current flows to the load instead of charging the battery. Use a fuse between battery and YRM2.DIODE!

Fig. 23-4 **Wiring diagram, 10A Battery back-up**

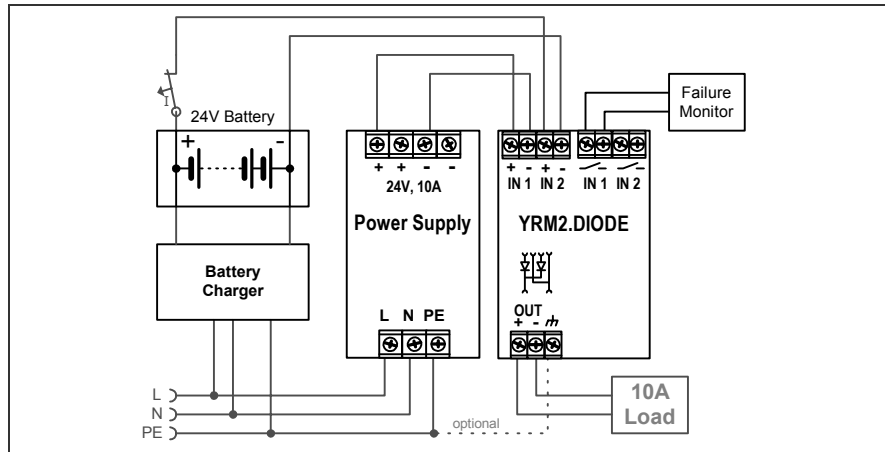

23.6. REDUNDANCY FOR SENSITIVE LOADS

Cost effective solution to get redundant power for a PLC or controller system.

Standard design:

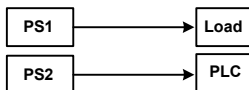

Improved approach:

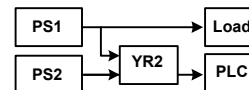
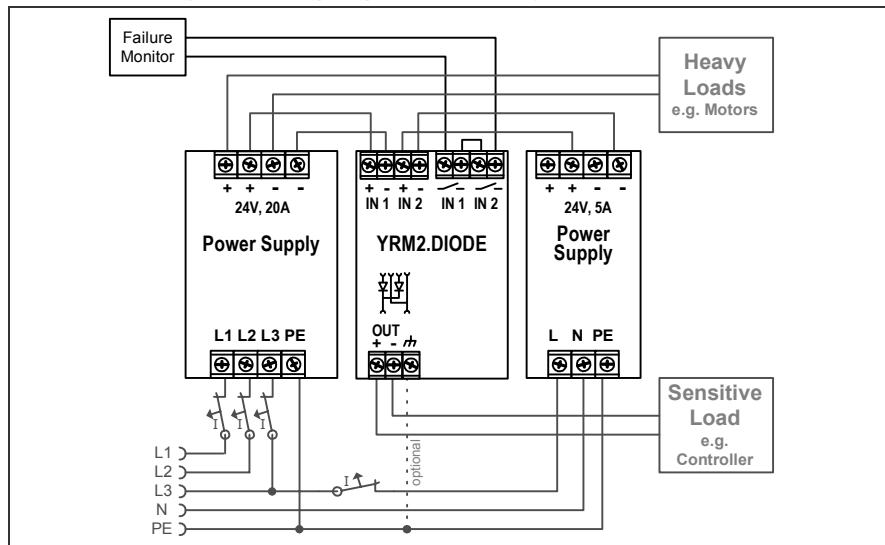

Fig. 23-5 **Wiring diagram, Redundancy for Sensitive Loads**



23.7. DECOUPLING OF BUFFERED BRANCHES

Buffer energy supplied from a DC-UPS or buffer module is not wasted in "power branches".

Please note:

Set output voltage of the power supply to a level that the buffer unit or DC-UPS will not start unexpected. Take the voltage drop of the YRM2.DIODE into account.

Fig. 23-6 **Wiring diagram, Decoupling of Buffered Branches**

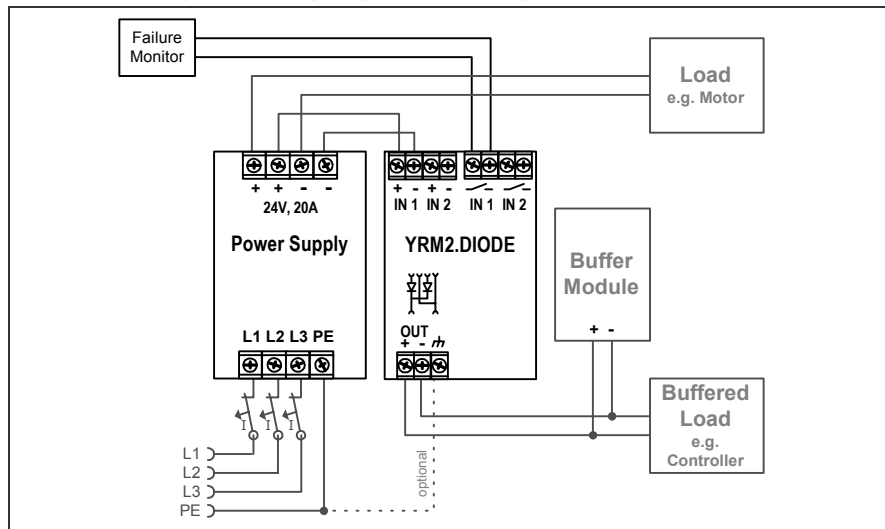

23.8. USE IN A TIGHTLY SEALED ENCLOSURE

When the redundancy module is installed in a tightly sealed enclosure, the temperature inside the enclosure will be higher than outside. The inside temperature defines the ambient temperature for the redundancy module.

Results from such an installation:

Power supply is placed in the middle of the box, no other heat producer inside the box

Enclosure: Rittal Typ IP66 Box PK 9516 100, plastic, 110x180x165mm

Load: 24V, 16A; (=80%) load is placed outside the box

Input: 24Vdc

Temperature inside enclosure: 58.8°C (in the middle of the right side of the power supply with a distance of 2cm)

Temperature outside enclosure: 24.6°C

Temperature rise: 34.2K

Mounting Orientations

Mounting orientations other than vertical require a reduction in continuous output current or a limitation in the max. allowed ambient temperature. The amount of reduction influences the lifetime expectancy of the power supply. Therefore, two different derating curves for continuous operation can be found below:

Curve A1 Recommended output current.

Curve A2 Max allowed output current (results approx. in half the lifetime expectancy of A1).

Fig. 23-7
Mounting Orientation A
Standard Orientation

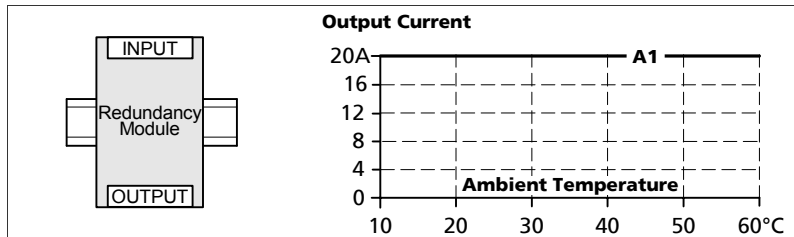

Fig. 23-8
Mounting Orientation B
(Upside down)

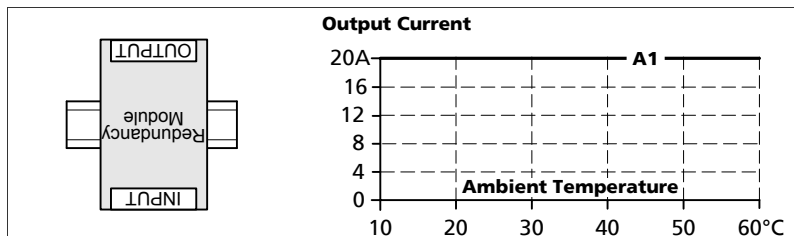

Fig. 23-9
Mounting Orientation C
(Table-top mounting)

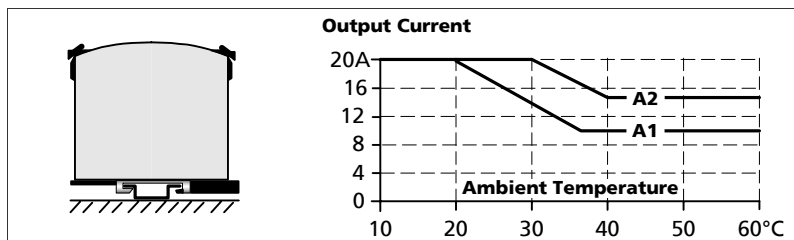

Fig. 23-10
Mounting Orientation D
(Horizontal cw)

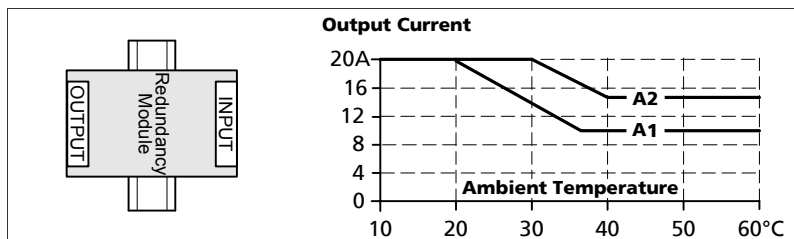

Fig. 23-11
Mounting Orientation E
(Horizontal ccw)

