

## Features:

- Universal AC input / Full range
- Programmable output Voltage (0% ~ 105%)
- Programmable output Current (0% ~ 105%)
- High power density 16.3W / inch<sup>3</sup>
- Forced current sharing at parallel operation
- Constant current limit
- Selectable +5V / 0.5A or +9V / 0.3A auxiliary output
- Power OK signal
- Remote ON / OFF, Remote sense function
- Protection: OVP, OLP, OTP, SCP, Fan failure



MODEL		AEK-3K12	AEK-3K15	AEK-3K24	AEK-3K30	AEK-3K36	AEK-3K48	AEK-3K60
Output	DC Voltage Range	12V	15V	24V	30V	36V	48V	60V
	Rated Current	200A	160A	125A	100A	83.5A	62.5A	50A
	Current Range	0~200A	0~160A	0~125A	0 ~ 100A	0 ~ 83.5A	0 ~ 62.5A	0 ~ 50A
	Rated Power	2400W	2400W	3000W	3000W	3006W	3000W	3000W
	Ripple & Noise (Max.)	Note.2 150mVp-p	150mVp-p	200mVp-p	200mVp-p	200mVp-p	200mVp-p	300mVp-p
	Voltage Adj. Range	±5.0% Typical adjustment by potentiometer. (VR1)						
	Voltage Tolerance	Note.3 ±2.0%						
	Line Regulation	±1.0%						
	Load Regulation	±1.0%						
	Setup, Rise Time	800ms, 50ms at full load						
Hold Up Time (Typ.)	14ms / 230VAC at full load							
Input	Voltage Range	Note.4 90 ~ 264VAC						
	Frequency Range	47 ~ 63Hz (Refer to output load de-rating curve)						
	Power Factor (Typ.)	0.95 / 230VAC, 0.98 / 115VAC at full load						
	Efficiency (Typ.)	88%	89%	91%	91%	92%	92%	93%
	AC Current (Typ.)	19.7A / 115VAC (2000W), 14.5A / 230VAC (3000W)						
	Inrush Current (Typ.)	33A / 115VAC, 65A / 230VAC						
Leakage Current	< 2.5mA / 240VAC							
Protection	Over Load	105% rated output power Protection type: Constant current limit						
	Over Voltage	Variable OVP, 120 ± 7% Vout. Refer to VCI VS OVP curve. Protection type: Latch-style (Recovery after reset AC power ON or inhibit)						
	Over Temperature	85 ±5°C detect on heat sink of primary and secondary side Protection type: Auto recovery after temperature goes down						
Function	Auxiliary Power	Selectable +5V / 0.5A or +9V / 0.3A auxiliary output						
	Remote ON / OFF Control	By external switch						
	Power OK Signal	Open drain signal low when PSU turns on, Max. sink current: 20mA, Max. drain voltage: 40V.						
	Output Voltage Trim	Adjustment of output voltage is between 0 ~ 105% of rated output						
	Output Current Trim	Adjustment of output current is between 0 ~ 105% of rated output						
Parallel (Current Sharing)	Note.5	Please refer to function						
Environment	Working Temp.	-25 ~ +60°C (Refer to output load de-rating curve)						
	Working Humidity	20 ~ 90% RH non-condensing						
	Storage Temp. & Humidity	-40 ~ +85°C, 10 ~ 95% RH						
	Temp. Coefficient	±0.02% / °C (0 ~ 50°C)						
	Vibration	10 ~ 500Hz, 5G 10min. / 1 cycle, period for 60min. each along X, Y, Z axes Compliance to IEC 68-2-6, IEC 68-2-64						
Safety & EMC	Safety Standards	Meet UL 60950-1; EN 60950-1						
	Withstand Voltage	Note.7	I/P-O/P: 3KVAC (4242VDC), I/P-FG: 1.5KVAC (2121VDC), O/P-FG: 0.5KVAC (707VDC)					
	Isolation Resistance	I/P-O/P, I/P-FG, O/P-FG: 100M Ohms / 500VDC						
	EMI Conduction & Radiation	Certified EN 55022; EN 61204-3; EN 61000-6-3						
	Harmonic Current	Certified EN 61000-3-2; EN 61000-3-3						
EMS Immunity	Note.6	Certified EN 55024; EN 61204-3; EN 61000-6-1; IEC 61000-4-2, 3, 4, 5, 6, 8, 11						
Others	Cooling	Load and temperature control fan						
	Dimension (WxHxD)	170x63.5x280 mm / 6.693x2.500x11.024 inch						
	Packing	3.8kg; 4pcs / 16.2kg						
Note	<p>1. All parameters NOT specially mentioned are measured at 230VAC input, rated load and 25°C of ambient temperature.</p> <p>2. Ripple &amp; noise are measured at 20MHz of bandwidth by using a 12" twisted pair-wire terminated with a 0.1uF &amp; 47uF parallel capacitor.</p> <p>3. Tolerance: includes set up tolerance, line regulation and load regulation.</p> <p>4. De-rating may apply in low input voltage. Please check the de-rating curve for more details.</p> <p>5. In parallel connection only one unit will operate if the total output load is less than 5% of the rated power.</p> <p>6. The power supply is considered a component which will be installed into a final equipment. The final equipment must be re-confirmed that it still meets EMC directives.</p> <p>7. Conduct this test without enclosure.</p>							

## Mechanical Specification:

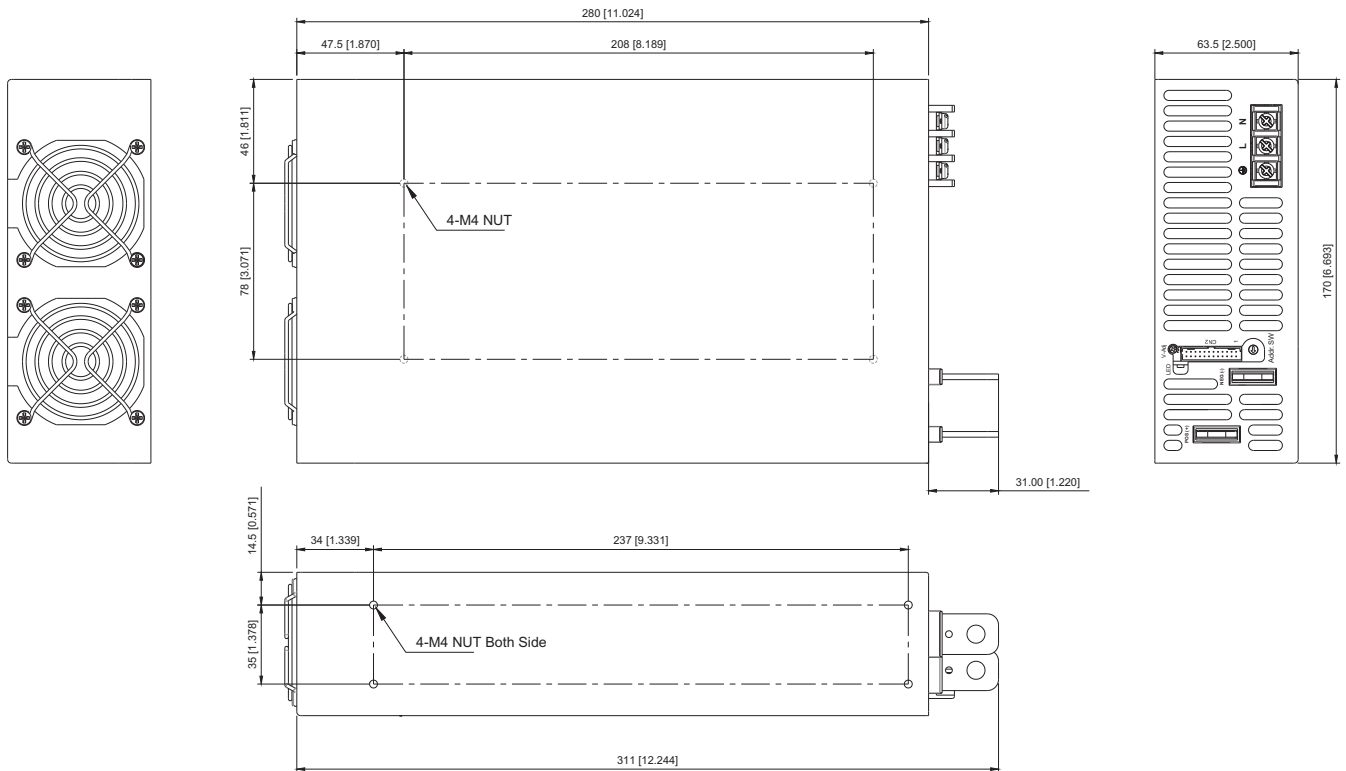

### AC Input Terminal Pin No. Assignment

Pin No.	Assignment
1	ACL
2	ACN
3	⏏







### Control pin number assignment (CN2): JST S24B-PHDSS or equivalent

Pin No.	Assignment	Pin No.	Assignment	Pin No.	Assignment	Pin No.	Assignment	Pin No.	Assignment	Mating Housing / Contact	
1	NC.	6	SDA	11	ACI	16	GND	21	VS-	JST PHDR-24VS or equivalent	JST SPHD-002T-P0.5 or equivalent
2	NC.	7	AUX	12	GND	17	PAR	22	VO-		
3	AUX	8	GND	13	EN+	18	VSET	23	VS+		
4	GND	9	VCI	14	AUX	19	POK	24	VO+		
5	SCL	10	GND	15	EN-	20	GND				

## CN2 Function Description:

Pin No.	Function	Description	Pin No.	Function	Description
1	NC.		13	EN+	Inhibit ON/OFF (+)
2	NC.		14	AUX	+5V / 0.5A, +9V / 0.3A Auxiliary power
3	AUX	+5V / 0.5A, +9V / 0.3A Auxiliary power	15	EN-	Inhibit ON/OFF (-)
4	GND	Ground	16	GND	Ground
5	SCL	Serial Data used in the I <sup>2</sup> C interface	17	PAR	Parallel operation current share
6	SDA	Serial Data used in the I <sup>2</sup> C interface	18	VSET	Aux output set
7	AUX	+5V / 0.5A, +9V / 0.3A Auxiliary power	19	POK	Power OK
8	GND	Ground	20	GND	Ground
9	VCI	V Program	21	VS-	Remote sense (-)
10	GND	Ground	22	VO-	Negative output voltage
11	ACI	I Program	23	VS+	Remote sense (+)
12	GND	Ground	24	VO+	Positive output voltage

## LED Status:

LED	LED Signal	Status
Solid(Green)		Power OK (Local mode)
Solid(Orange)		Power OK (Remote mode)
Slow Blink(Green)		Power Standby
Fast Blink(Red)		Over Voltage Protection ( OVP )
Solid(Red)		Over Load Protection ( OLP )
Slow Blink(Red)		Over Temperature Protection ( OTP )
Intermittent Blink(Red)		Fan Failure
Interlace Blink(Red)		Power Failure

\*Local mode : Use ACI/VCI control output current and voltage.  
Remote mode : Use RS-232 or I<sup>2</sup>C command control output current and voltage.

## De-rating Curve:

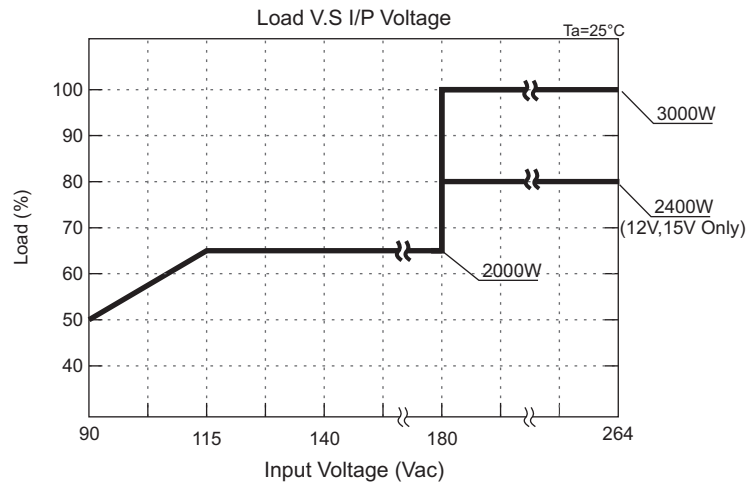
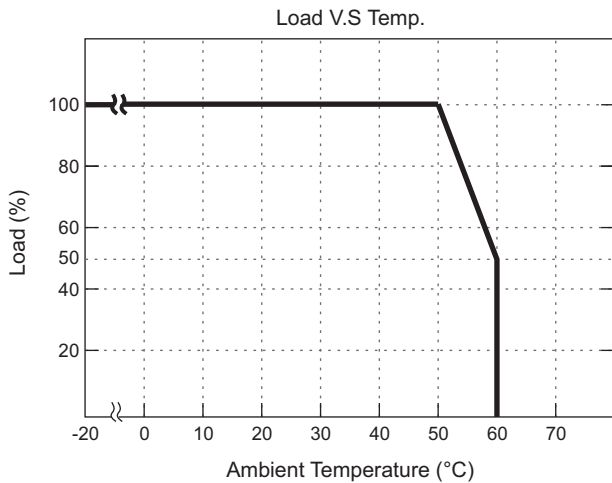

## CMD VS Output Curve:

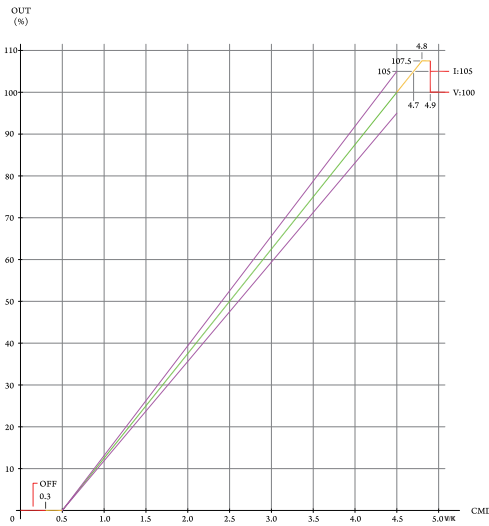

## VCI VS OVP Curve:

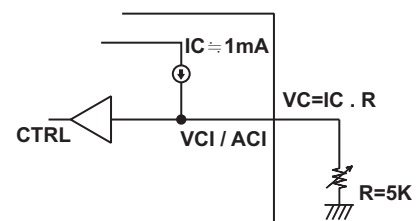
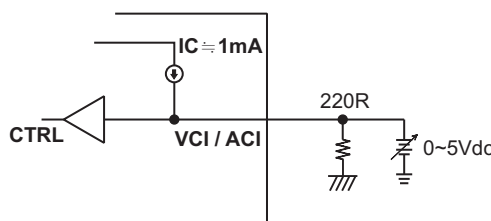
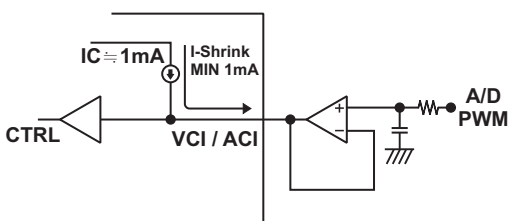
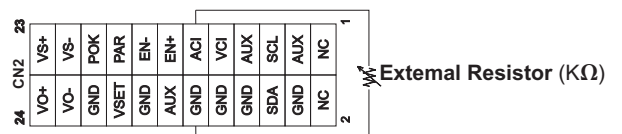
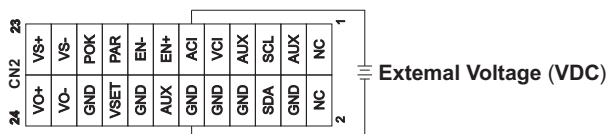
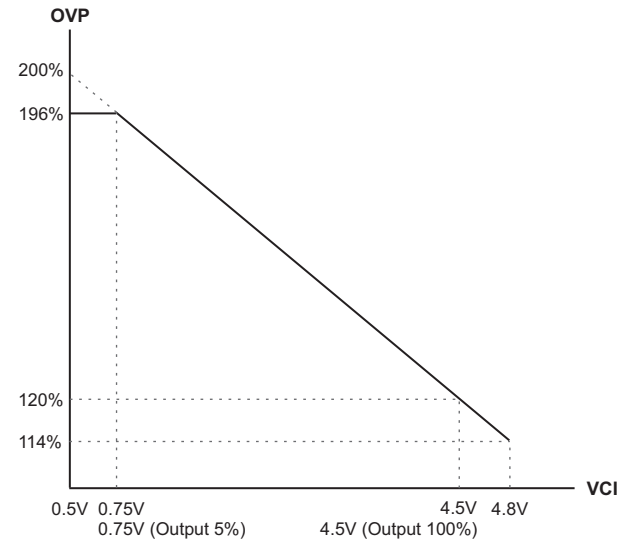

## Remote ON/OFF:

(A) Default Setting

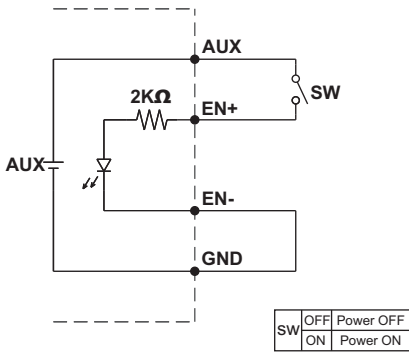

(A) Using internal 5V auxiliary source

(B)

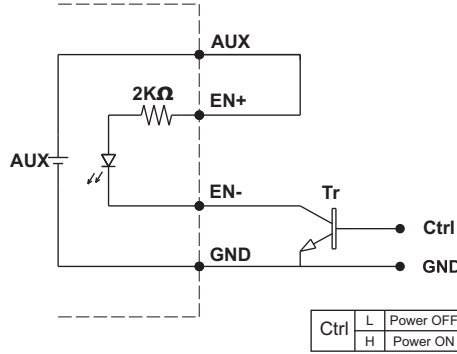

(B) ON / OFF Control by NPN transistor

(C)

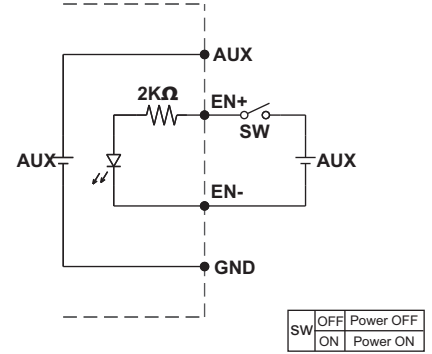

(C) Using external voltage source

## Power OK Signal:

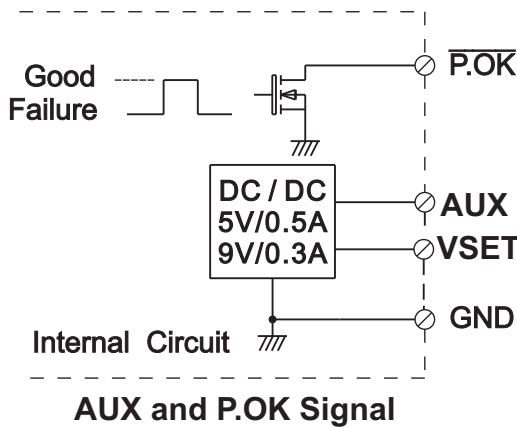

\*Place an additional capacitor to have a better performance of auxiliary power operation.

\*The grounding of "AUX" power should be connected to "GND" port. If "V-" is connected as Grounding, make sure to short the GND and V- ports.

VSET	Open	5V	(Default Setting)
	Short To GND	9V	

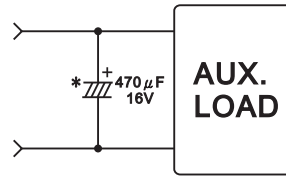

1. Remote Sense

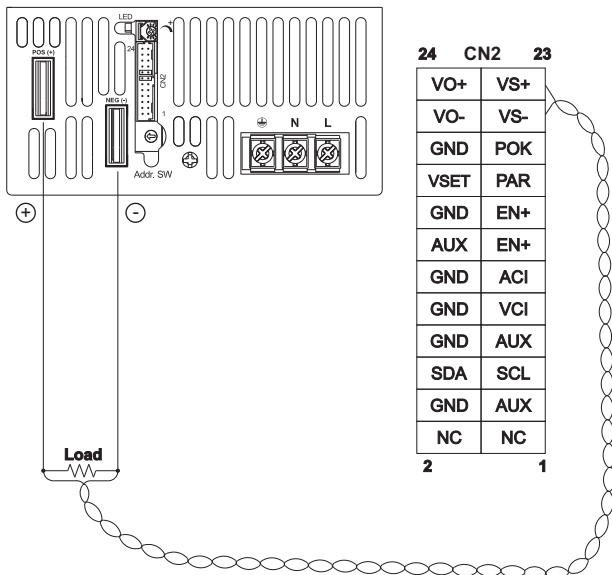

2. Local Sense (Default setting)

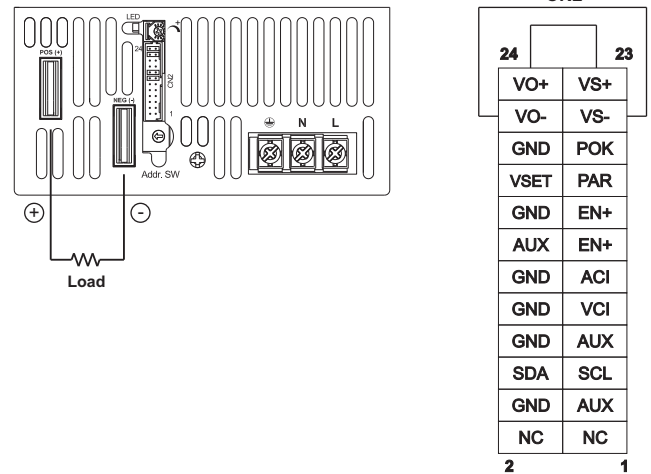

### 3. Current Sharing with Remote Sensing

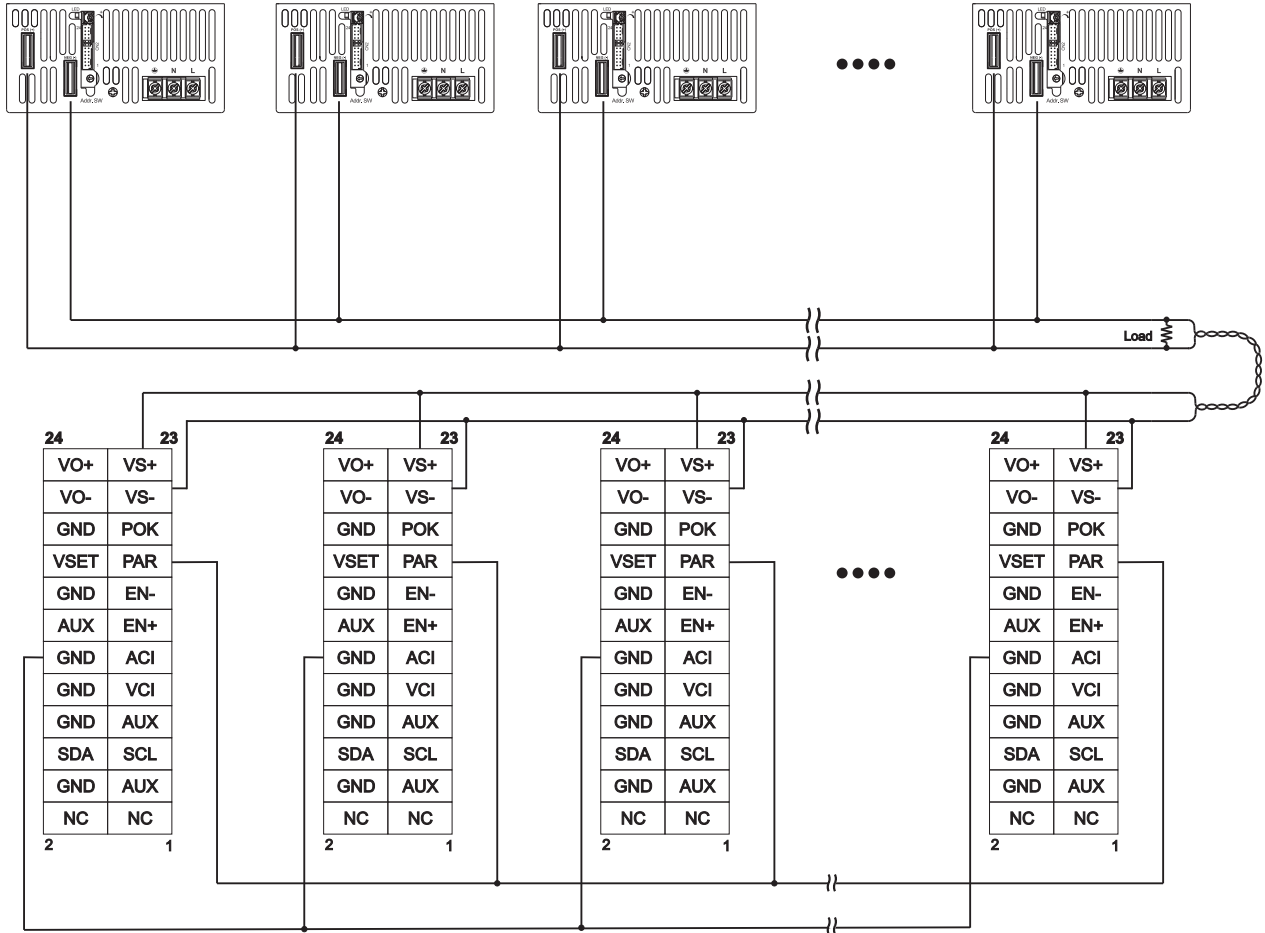

### 4. Current Sharing with Local Sensing

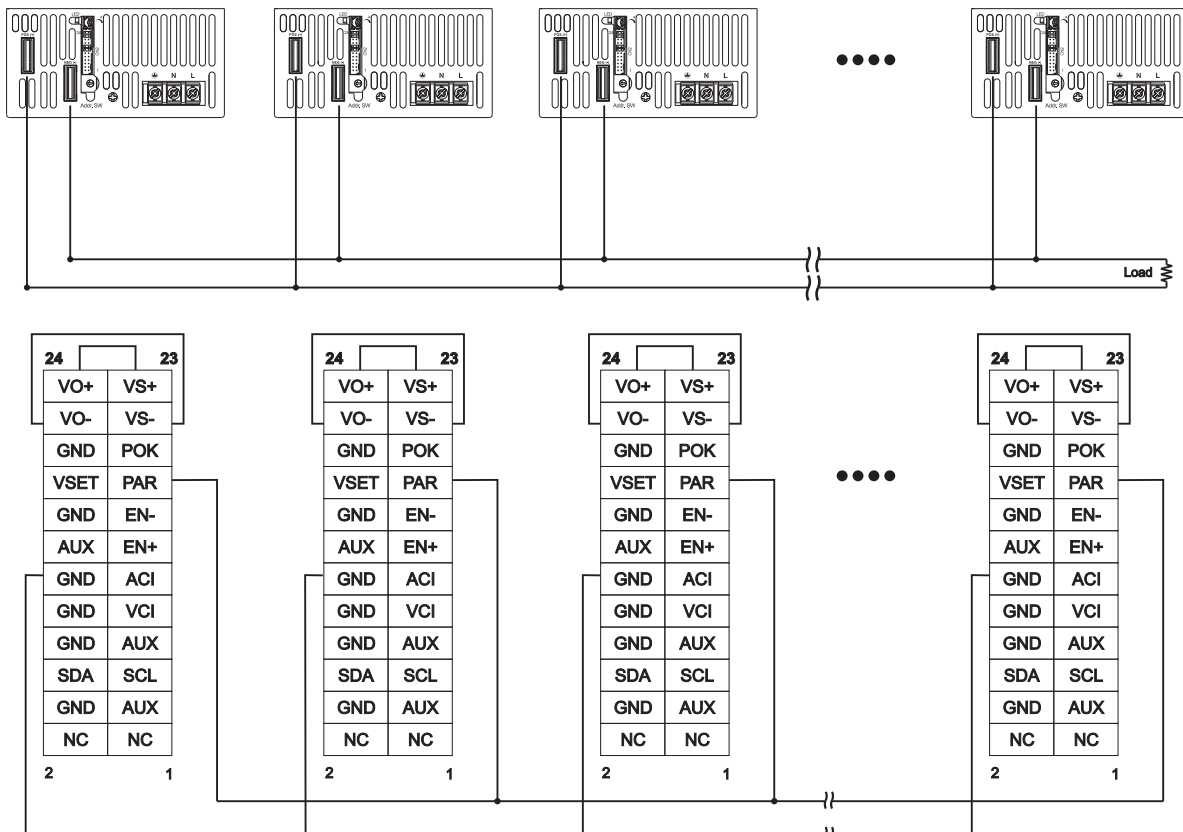

## Installation Instruction:

### 1. Mounting Directions

1-1 Recommended standard mounting methods:

(a)

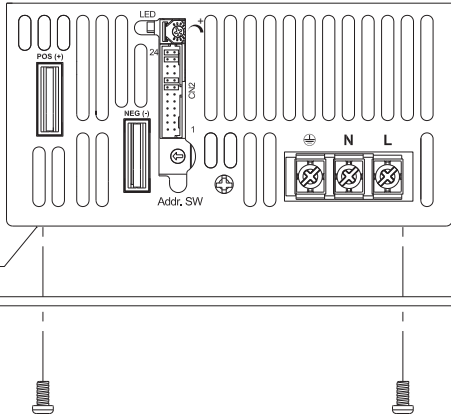

4-M4  
L=4mm max.

(b)

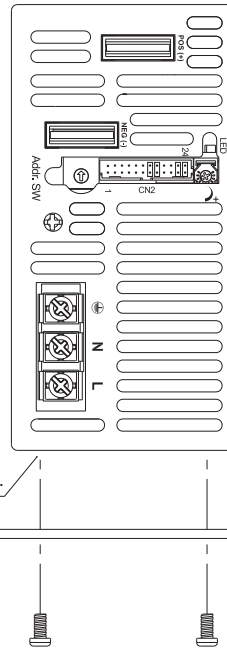

4-M4  
L=4mm max.

(c)

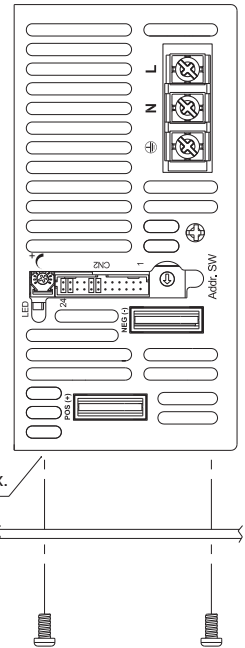

4-M4  
L=4mm max.

### 2. Mounting Method

2-1 There are ventilating holes on the front and back side panels, do not obstruct; allow 50mm at least for air flow.

2-2 The Maximum allowable penetration of screw is 4mm.  
Incomplete threading should not be penetrated.

2-3 Recommended the torque of mounting screw:  
M4 screw: 1.27N • m (13.0kgf • cm)

