

BR3U - Q8290 SERIES

Battery Charging System: 170 - 700 Watts

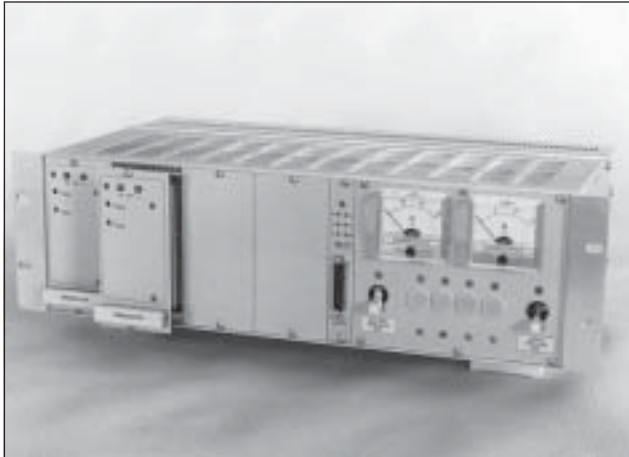

Specifications

INPUT VOLTAGE:	115 / 230 VAC link selectable
FREQUENCY:	47 - 63Hz
INPUT PROTECTION:	Inrush current limiting, thermal fuse
INPUT ISOLATION:	Input - output: 4300 VDC Input - chassis: 2250 VDC Output - chassis: 500 VDC
SAFETY:	Designed in accordance with IEC950 and EN60950
EMI/RFI:	EN55022 Class B conducted
EFFICIENCY:	Model dependent, typically 80%
OUTPUT VOLTAGE:	12V nominal: 13.5 VDC 24V nominal: 27.0 VDC 48V nominal: 54.0 VDC 110V nominal: 121.0 VDC Other voltages on request
VOLTAGE ADJUSTMENT:	Front panel adjustment 5%
SYSTEM OUTPUT POWER:	170 - 700 watts
MODULE OUTPUT POWER:	REW150: 170 watts 3U x 12 HP x 160mm Eurocard
LINE REGULATION:	Typically $\pm 5\%$
LOAD REGULATION:	$\pm 1.0\%$ from 10% - 100% load
OUTPUT RIPPLE:	Typically 1% of output voltage
TEMPERATURE DRIFT:	$\pm 0.03\%$ per $^{\circ}\text{C}$
OPERATING TEMP:	0°C to $+50^{\circ}\text{C}$ at full load.
COOLING:	Free air convection
OUTPUT PROTECTION:	Rectangular current limiting with auto-recovery. Overvoltage protection.
METERS:	Battery volt meter and load ammeter
LED INDICATORS:	With buzzer warning:- • AC fail • Rectifier/module fail • High volts • Low volts • Battery breaker open
ALARMS (ALM1935):	Voltage free relay contacts:- • AC fail • Rectifier/module fail • High volt alarm • Low volt alarm • Battery breaker open
ALARM CONNECTOR:	All alarm conditions are available on a 25 pin D-connector on the front panel.
SYSTEM ASSEMBLY:	19 inch x 3U x 260mm rack assembly AC input connections: IEC socket DC output: via screw terminals

Features

- Input 115 / 230 VAC, other options on request
- Output 12 ~ 130 VDC, other options on request
- 3U x 19 inch rack assembly, fully wired
- N+1 redundancy of rectifiers @ 170W each
- System can take up to four rectifiers - 700W without redundancy or 540W with redundancy
- Hot swap capability under full load
- Front panel test points and volts adjustment
- Alarms and LED indicators, Volt and Amp meters
- Low battery disconnect
- Input AC breaker, battery breaker
- DC distribution breakers option
- Customised solutions on request

Rectifier Model	Output		Power W
	V	A	
REW150 - 13 - Q8290	13.5V	12.8A	170W
REW150 - 27 - Q8290	27.0V	6.4A	170W
REW150 - 54 - Q8290	54.0V	3.2A	170W
REW150 - 120 - Q8290	120.0V	1.4A	170W
System Assembly			
BR3U - 13 - Q8290	12V Rack System		
BR3U - 27 - Q8290	24V Rack System		
BR3U - 54 - Q8290	48V Rack System		
BR3U - 120 - Q8290	120V Rack System		

BR4U - Q8268 SERIES



Battery Charging System: 300 - 1500 Watts



Specifications

INPUT VOLTAGE:	115 / 230 VAC link selectable
FREQUENCY:	47 - 63Hz
INPUT PROTECTION:	Inrush current limiting, thermal fuse
INPUT ISOLATION:	Input - output: 4300 VDC Input - chassis: 2250 VDC Output - chassis: 500 VDC
SAFETY:	Designed in accordance with IEC950 and EN60950
EMI/RFI:	EN55022 Class B conducted
EFFICIENCY:	Model dependent, typically 80%
OUTPUT VOLTAGE:	12V nominal: 13.5 VDC 24V nominal: 27.0 VDC 48V nominal: 54.0 VDC 110V nominal: 121.0 VDC Other voltages on request
VOLTAGE ADJUSTMENT:	Front panel adjustment 5%
SYSTEM OUTPUT POWER:	300 ~ 1500 watts
MODULE OUTPUT POWER:	LOT65 Module: 300 watts 4U x 16 HP x 320mm Eurocard HBC419 Module: 500 watts 4U x 16HP x 320mm Eurocard
LINE REGULATION:	Typically $\pm 5\%$
LOAD REGULATION:	$\pm 1.0\%$ from 10% - 100% load
OUTPUT RIPPLE:	Typically 1% of output voltage
TEMPERATURE DRIFT:	$\pm 0.03\%$ per $^{\circ}\text{C}$
OPERATING TEMP:	0 $^{\circ}\text{C}$ to +50 $^{\circ}\text{C}$ at full load.
COOLING:	Free air convection
OUTPUT PROTECTION:	Rectangular current limiting with auto recovery. Thermal shutdown with auto recovery
OVP:	Yes
METERS:	Battery volt meter and load ammeter
LED INDICATORS:	With buzzer warning:- • AC fail • Rectifier/module fail • Low battery • Battery disconnect • Battery breaker open
ALARMS:	Voltage free relay contacts:- • AC fail • Rectifier/module fail • Low battery • Battery disconnect
SYSTEM ASSEMBLY:	19 inch x 4U x 385mm rack assembly Input connections: IEC socket Output / Alarms: via screw terminals

Features

- Input 115 / 230 VAC, other options on request
- Output 12 ~ 130 VDC, other options on request
- 4U x 19 inch rack assembly, fully wired
- Any number of racks can be connected in parallel
- N+1 redundancy of rectifier modules
- 300W or 500W rectifier modules with Hot Swap capability under full load
- System can take up to three 300W or 500W modules
- Alarms and LED indicators, Volt and Amp meters
- Low battery disconnect
- Input AC breaker, battery breaker
- Customised solutions on request

Rectifier Model	Output		Power W
	V	A	
LOT65 - 13 - Q8268	13.5V	22A	300W
LOT65 - 27 - Q8268	27.0V	12A	300W
LOT65 - 54 - Q8268	54.0V	5.5A	300W
LOT65 - 120 - Q8268	120.0V	2.5A	300W
HBC419 - 13 - Q8268	13.5V	20A	270W
HBC419 - 27 - Q8268	27.0V	18.5A	500W
HBC419 - 54 - Q8268	54.0V	9.2A	500W
System Assembly			
BR4U - 13 - Q8268	12V Rack System		
BR4U - 27 - Q8268	24V Rack System		
BR4U - 54 - Q8268	48V Rack System		
BR4U - 120 - Q8268	120V Rack System		

BR RECTIFIER SERIES

AC/DC Modular Rectifier System: 300 - 2500 Watts



Features

- Turn-key modular battery charger system
- 6U x 19" rack or wall mounting system
- Complete with meters distribution panel and controls
- Four alarms for external signalling, with LED's
- Plug-in 300W or 500W rectifiers
- n+1 redundancy
- 12, 24, 48 and 120V systems available
- Optional power factor corrected rectifiers

A complete rectifier/battery charging system, developed for powering critical DC systems.

The building block of the system is our LOT65 300W or HBC419 500W plug-in rectifiers. The system can start with one 300W or 500W module and end with up to five modules (for a total of 2500W) added to the standard system.

All major functions, AC Fail, Module Fail, Battery Low and Battery Disconnect are monitored by the alarm board and these alarms are available for remote monitoring via voltage-free Form C relay contacts.

Options include our PFC419 rectifiers with PFC as well as a 1000W rectifier plugin module which increases the output power to 5000W in 8U x 19in Rack System.

Specifications

INPUT VOLTAGE:	115/230 VAC link selectable.
FREQUENCY:	47- 63Hz (other options on request)
RECTIFIER SPECS:	LOT65: 12~120V 300W module, 4U x 304mm x 16HP with H15 DIN connector. HBC419: 24~120V 500W module, 4U x 304mm x 16HP with H15 DIN connector.
INPUT PROTECTION:	Thermal fuse and inrush current limiting
ISOLATION:	Input - output: 4300 VDC Input - chassis: 2250 VDC Output - chassis: 500 VDC
EFFICIENCY:	Typically 85% at rated input and output power
TEST POINTS:	Each rectifier has front panel voltage test points and rectifier voltage adjustment
PARALLEL OPERATION:	Rectifiers of the same model can be paralleled for any power requirement, consult office or manual for details.
SAFETY:	Rectifier modules are designed to meet IEC950/EN60950/AS3260 standards.
REDUNDANCY:	Each rectifier is fitted with an isolation diode for n+1 redundancy operations and hot swap.
LINE REGULATION:	±0.5% over input range
LOAD REGULATION:	±1.0% including redundancy diode
RFI:	Meets requirement of EN55022 level A
OUTPUT RIPPLE & NOISE:	Wide band noise: 1% of output voltage pk-pk and 0.2%rms. Audio band: maximum 32dB
OUTPUT PROTECTION:	Current limiting with short circuit protection and overvoltage protection
TEMPERATURE DRIFT:	0.03% per °C.
OPERATING TEMP:	0°C to 50°C with good convection cooling, consult office for higher operating level.
SHELF SPEC'S:	The shelf contains the following: <ul style="list-style-type: none"> • Plug-in module compartment/assembly and associated wiring. • Load ammeter, battery volt meter and LED's. • Alarm board.
BREAKERS:	<ul style="list-style-type: none"> • AC input breaker, battery circuit breaker. • Eight distribution breakers at 5A each.
ALARMS & INDICATORS:	<ul style="list-style-type: none"> • LED's for AC fail, converter fail, low battery battery disconnect and buzzer. • Relay contacts for AC fail, converter fail, low battery and battery disconnect.
MECHANICAL:	Complete system is 6U x 19in rack mounting or wall mounting consisting of: <ul style="list-style-type: none"> • 4U x 19in rack mounting rectifier assembly • 2U x 19in rack mounting assembly containing meter, breakers & distribution.

BR RECTIFIER SERIES

AC/DC Modular Rectifier System: 300 - 2500 Watts

48V SYSTEM BLOCK DIAGRAM

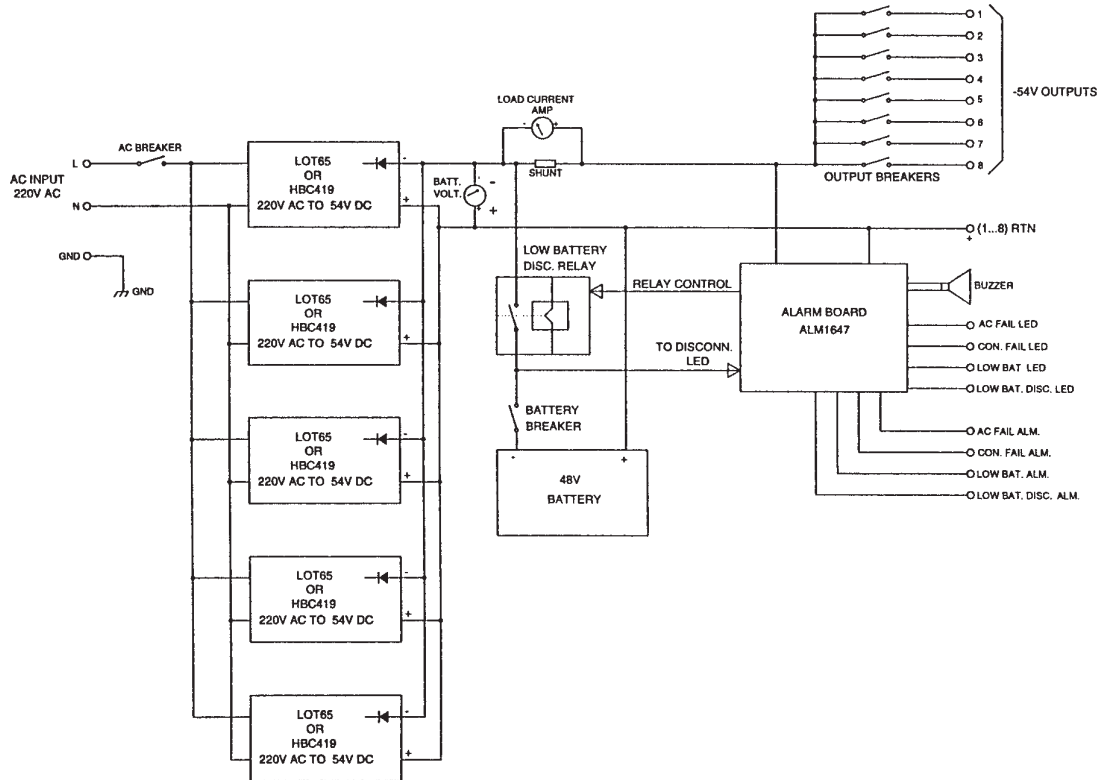

OPTIONAL PFC6000 MODULAR RECTIFIER SYSTEM



- The system is comprised of six 1000W power factor corrected plug-in modules in a 4U x 19" Rack assembly.
- Each module can supply 1200W @ 230VAC input or 1000W @ 110VAC
- At 230VAC input, the system can provide:
12V @ 580A, 24V @ 290A, 48V @ 145A
- For AC input redundancy, the modules are wired internally in pairs at the input.
This also allows for a three phase 415V & neutral supply.
- Forced air cooling is provided by a uniquely designed fan unit installed at the rear of the system.
- The PFC6000 can be designed to your voltage specification and any modifications are welcomed.