



BATTERY MODULES

A modular concept allows the user to meet individual application demands and is available with two different options:

You can order the module with an assembled battery or you can choose only the bracket allowing the mounting of individual batteries such as long life or higher current which achieves a longer buffer-time. The mounting bracket allows the battery to be assembled just in time avoiding outdated batteries due to limited shelf life.

- Two mounting options:
DIN-Rail or panel/wall mounting
- Easy access to the terminals and the fuse
- Heavy duty fuse holder and spare fuse included

DATA

Battery

Maintenance free valve regulated lead acid battery

Battery voltage nom 12Vdc

Battery capacity nom 7Ah

Fuse

Blade terminal fuse nom 30A ATO®
(257 030 Littelfuse)

Terminals and Wiring

Type Screw terminals

Solid wire nom 2.5-4mm²

Stranded wire nom 2.5-4mm²

American wire gauge max 12 AWG

Wire stripping length nom 7mm / 0.275"

Tightening torque nom 0.8Nm / 7lb.in

Ambient Temperature

Operation min +0°C to +40°C

Storage and transport min -20°C to +50°C

Dimensions and Weight

Width nom 155mm / 6.1"

Height nom 124mm / 4.88"

Depth nom 112mm / 4.41"

Weight with battery 3.2KG

The DIN-rail height when used must be added to the depth to calculate the total required installation unit depth.

DATA

Instructions for Use and Disposal of the Battery

- Place the battery module outside the cabinet or in the coolest area when used inside the cabinet.
- Use wires no smaller than 2.5mm² (or 12 AWG) and not longer than 2x1.5m (cord length 1.5m).
- Disconnect battery fuse before working on the battery or on the DC-UPS.
- To replace battery, loosen screw with only one turn and slide the mounting bracket up.
- For storage, installation and operation, the requirements of the EN 50272-2 as well as other national regulations must be observed.
- Ensure sufficient ventilation for the battery.
- Always dispose the batteries through a recycling organisation. Batteries must be completely discharged before recycling.

Warranty

2 Year limited warranty except battery as battery is considered as a service part. Special conditions are part of our general terms and conditions. Do not store the battery longer than 9 month without supplementary charge or performance might change.

Battery, terminal block, cables, fuse and fuse holder are **UL**-approved components.

PHYSICAL DIMENSIONS

Fig. 1 Front view

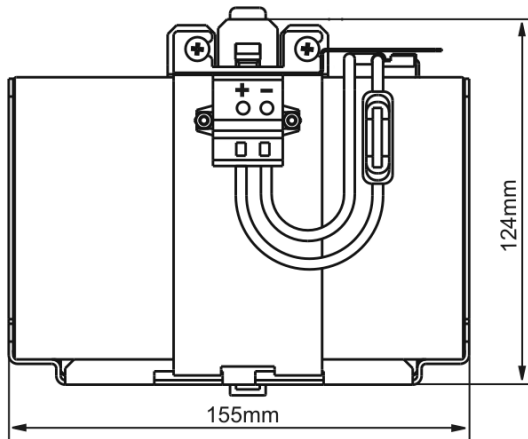
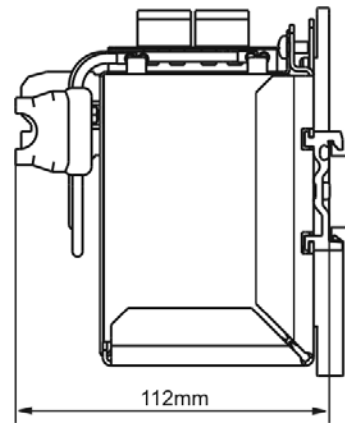
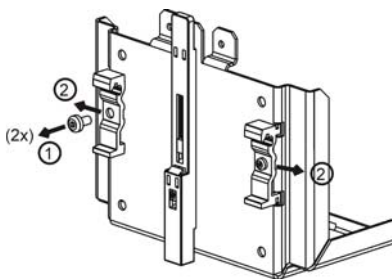

Fig. 2 Side view



PANEL/WALL MOUNTING

Fig. 3 Detaching DIN-Rail brackets



Detach the two aluminium brackets by removing the two screws with a Torx screwdriver (Torx 10).

Fig. 4 Detach slide

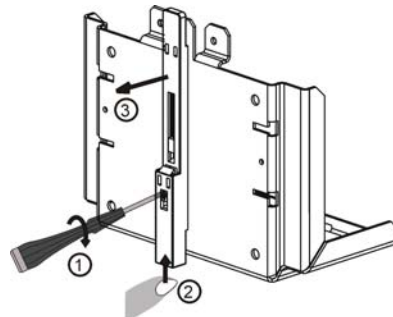

Remove the plastic lock mechanism by using a flat-blade screwdriver to press the lock downwards while pushing the plastic slide upwards at the same time. Detach the plastic slide.

Fig. 5 Panel/wall mount

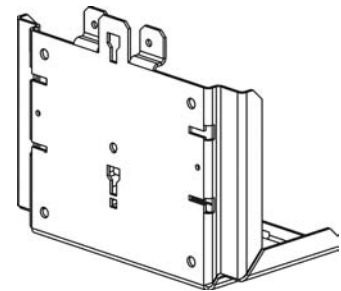

Panel/wall mounting is possible by using either the four holes on the rear or the bottom of the unit. See hole pattern below.

Fig. 6 Rear hole pattern

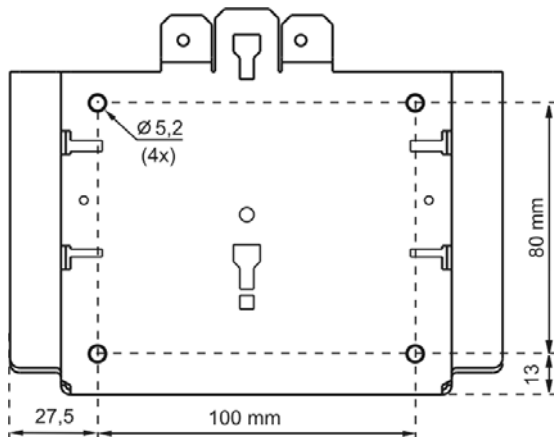
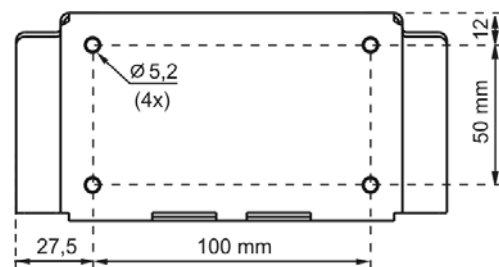

Fig. 7 Bottom hole pattern



All parameters are specified at 25°C ambient unless otherwise noted.

The information presented in this datasheet is believed to be accurate and reliable and may change without notice