



POWER SUPPLY

- AC 100-240V Wide-range Input
- Efficiency up to 94.0%
- Width only 82mm
- 150% Peak Load Capability
- Active Power Factor Correction, PFC
- DC Input from 88 to 375Vdc
- Short-term Operation from 60Vac to 300Vac
- Full Power Between -25°C and +60°C
- Negligibly Low Inrush Current
- DC-OK Relay Contact
- Quick-connect Spring-clamp Terminals

1. GENERAL DESCRIPTION

The most outstanding features of this Dimension Q-Series power supply are the high efficiency and the small size, which are achieved by a synchronous rectification and further novel design details.

With short-term power capability of 150% and built-in large sized output capacitors, these features help start motors, charge capacitors and absorb reverse energy. A wide range input voltage design and a negligible low input inrush current make installation and usage simple. Diagnostics are easy due to the DC-ok relay, a green DC-ok and a red overload LED.

Unique quick-connect spring-clamp terminals allow a safe and fast installation. Many global approvals make this unit suitable for nearly every situation.

QS20-Series Related products

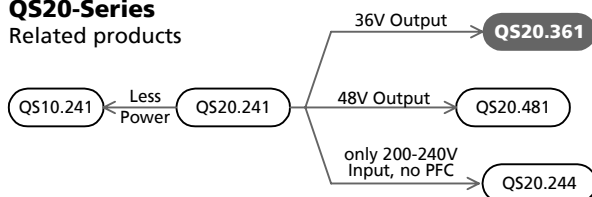

2. SHORT-FORM DATA

| | | |
|-------------------|------------------|------------------|
| Output voltage | DC 36V | |
| Adjustment range | 36-42V | |
| Output current | 13.3A | continuous, 36V |
| | 20.0A | for typ. 4s, 36V |
| Output power | 480W | continuous, 36V |
| | 720W | for typ. 4s, 36V |
| Output ripple | < 100mVpp | 20Hz to 20MHz |
| Input voltage | AC 100-240V | ±15% |
| Mains frequency | 50-60Hz | ±6% |
| AC Input current | 4.56 / 2.48A | at 120 / 230Vac |
| Power factor | 0.95 / 0.90 | at 120 / 230Vac |
| AC Inrush current | typ. 9 / 7A peak | at 120 / 230Vac |
| DC Input voltage | DC 110-300V | -20%/+25% |
| DC Input current | 4.7 / 1.7A | at 110 / 300Vdc |
| Efficiency | 92.5 / 94.0% | at 120 / 230Vac |
| Losses | 38.9 / 30.6W | at 120 / 230Vac |
| Temperature range | -25°C to +70°C | operational |
| Derating | 12W/°C | +60 to +70°C |
| Hold-up time | typ. 32 / 51ms | at 120 / 230Vac |
| Dimensions | 82x124x127mm | WxHxD |

3. ORDER NUMBERS

| | | |
|--------------|-----------------|--------------------|
| Power Supply | QS20.361 | 36-42V unit |
| Accessory | ZM1.WALL | Wall mount bracket |
| | ZM15.SIDE | Side mount bracket |
| | YR2.DIODE | Decoupling module |

4. MARKINGS



INDEX PAGE

| | |
|--|----|
| 1. General Description | 1 |
| 2. Short-form Data | 1 |
| 3. Order Numbers | 1 |
| 4. Markings | 1 |
| 5. AC-Input | 3 |
| 6. Input Inrush Current | 4 |
| 7. DC-Input | 4 |
| 8. Output | 5 |
| 9. Hold-up Time | 7 |
| 10. DC-OK Relay Contact | 7 |
| 11. Efficiency and Power Losses | 8 |
| 12. Functional Diagram | 9 |
| 13. Front Side and User Elements | 9 |
| 14. Terminals and Wiring | 10 |
| 15. Reliability | 10 |
| 16. EMC | 11 |
| 17. Environment | 12 |
| 18. Protection Features | 13 |
| 19. Safety | 13 |
| 20. Dielectric Strength | 13 |
| 21. Approvals | 14 |

INDEX PAGE

| | |
|---|----|
| 22. Fulfilled Standards | 14 |
| 23. Used Substances | 14 |
| 24. Physical Dimensions and Weight | 15 |
| 25. Installation and Operation Instructions | 15 |
| 26. Accessory | 16 |
| 27. Application Notes | 17 |
| 27.1. Repetitive Pulse Loading | 17 |
| 27.2. Peak Current Capability | 18 |
| 27.3. Back-feeding Loads | 18 |
| 27.4. Charging of Batteries | 18 |
| 27.5. Output Circuit Breakers | 19 |
| 27.6. External Input Protection | 20 |
| 27.7. Parallel Use to Increase Output Power .. | 20 |
| 27.8. Parallel Use for Redundancy | 20 |
| 27.9. Daisy-Chaining of Outputs | 21 |
| 27.10. Series Operation | 21 |
| 27.11. Inductive and Capacitive Loads | 21 |
| 27.12. Operation on Two Phases | 22 |
| 27.13. Use in a Tightly Sealed Enclosure | 22 |
| 27.14. Mounting Orientations | 23 |

INTENDED USE

The power supply shall only be installed and put into operation by qualified personnel.

This power supply is designed for installation in an enclosure and is intended for the general use, such as in industrial control, office, communication, and instrumentation equipment. Do not use this device in aircraft, trains and nuclear equipment, where malfunctioning of the power supply may cause severe personal injury or threaten human life.

TERMINOLOGY AND ABBREVIATIONS

| | |
|--|--|
| PE and \oplus symbol | PE is the abbreviation for Protective Earth and has the same meaning as the symbol \oplus . |
| Earth, Ground | This document uses the term "earth" which is the same as the U.S. term "ground". |
| T.b.d. | To be defined, value or description will follow later. |
| AC 230V | A figure displayed with the AC or DC before the value represents a nominal voltage with standard tolerances (usually $\pm 20\%$) included. E.g.: DC 12V describes a 12V battery disregarding whether it is full (13.7V) or flat (10V) As long as not otherwise stated, AC 100V and AC 230V parameters are valid at 50Hz and AC 120V parameters are valid at 60Hz mains frequency. |
| 230Vac | A figure with the unit (Vac) at the end is a momentary figure without any additional tolerances included. |

DISCLAIMER

The information presented in this document is believed to be accurate and reliable and may change without notice.

Some parts of this unit are patent by PULS (US patent No 091662,063, Des. 424,529, ...).

No part of this document may be reproduced or utilized in any form without permission in writing from the publisher.

5. AC-INPUT

| | | | |
|-------------------|------|-------------|---|
| AC input | nom. | AC 100-240V | wide-range input, TN-, TT-, IT-Mains, see Fig. 5-1 |
| AC input range | min. | 85-276Vac | continuous operation |
| | min. | 60-85Vac | full power for 200ms, no damage between 0 and 85Vac |
| | min. | 276-300Vac | < 500ms |
| Input frequency | nom. | 50 – 60Hz | ±6% |
| Turn-on voltage | typ. | 82Vac | steady-state value, see Fig. 5-1 |
| Shut-down voltage | typ. | 64Vac | steady-state value, see Fig. 5-1 |
| | typ. | 53Vac | dynamical value |

| | | AC 100V | AC 120V | AC 230V | |
|-------------------|------|---------|---------|---------|--------------------------------|
| Input current | typ. | 5.47A | 4.56A | 2.48A | at 36V, 13.3A, see Fig. 5-3 |
| Power factor *) | typ. | 0.96 | 0.95 | 0.90 | at 36V, 13.3A, see Fig. 5-4 |
| Crest factor **) | typ. | 1.6 | 1.7 | 2.05 | at 36V, 13.3A |
| Start-up delay | typ. | 640ms | 610ms | 660ms | see Fig. 5-2 |
| Rise time | typ. | 210ms | 220ms | 85ms | 0mF, 36V, 13.3A, see Fig. 5-2 |
| | typ. | 210ms | 220ms | 90ms | 20mF, 36V, 13.3A, see Fig. 5-2 |
| Turn-on overshoot | max. | 75mV | 75mV | 75mV | see Fig. 5-2 |

*) The power factor is the ratio of the true (or real) power to the apparent power in an AC circuit.

***) The crest factor is the mathematical ratio of the peak value to RMS value of the input current waveform.

Fig. 5-1 Input voltage range

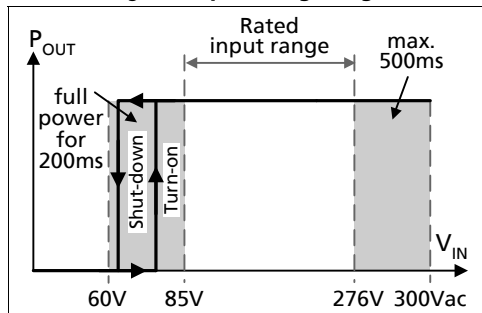

Fig. 5-2 Turn-on behavior, definitions

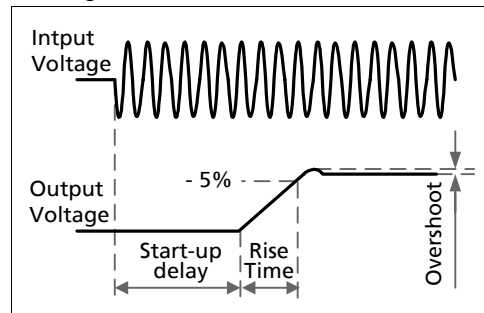

Fig. 5-3 Input current vs. output load at 36V

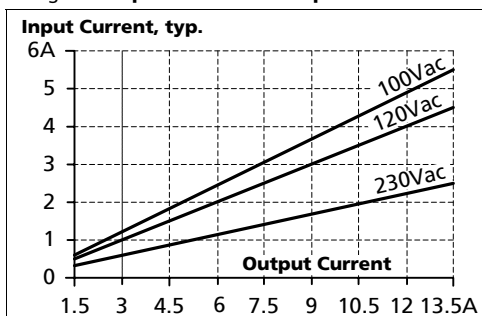
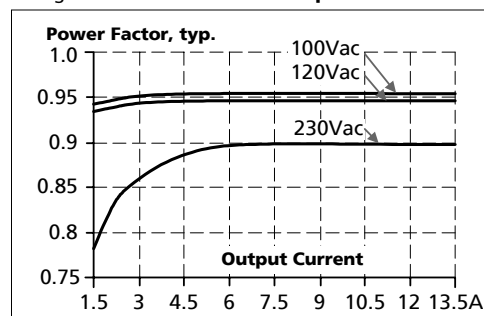

Fig. 5-4 Power factor vs. output load at 36V



6. INPUT INRUSH CURRENT

An active inrush limitation circuitry limits the input inrush current after turn-on of the input voltage. The charging current into EMI suppression capacitors is disregarded in the first millisecond after switch-on (EN 61204).

| | | AC 100V | AC 120V | AC 230V | |
|----------------|------|---------------------|---------------------|---------------------|---|
| Inrush current | max. | 13A _{peak} | 13A _{peak} | 13A _{peak} | -25°C to +70°C, mains interruptions > 750ms |
| | typ. | 11A _{peak} | 9A _{peak} | 7A _{peak} | -25°C to +70°C, mains interruptions > 750ms |
| Inrush energy | max. | 5A ² s | 5A ² s | 5A ² s | -25°C to +70°C, mains interruptions > 750ms |
| Inrush delay | typ. | 400ms | 400ms | 650ms | |

Fig. 6-1 Input inrush current, typical behavior

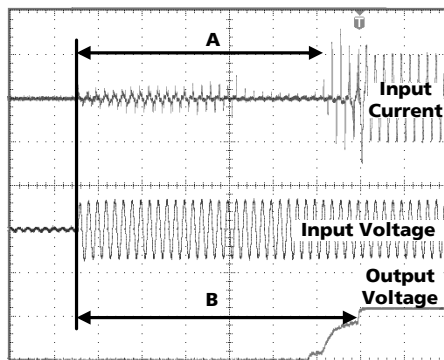

A: Inrush delay
B: Start-up delay
 Input: 230Vac
 Output: 36V, 13.3A
 Ambient: 25°C
 Upper curve: Input current 5A / DIV
 Medium curve: Input voltage 500V / DIV
 Lower curve: Output voltage 30V / DIV
 Time basis: 100ms / DIV

7. DC-INPUT

| | | | |
|-------------------|------|-------------|-----------------------------|
| DC input | nom. | DC 110-300V | |
| DC input range | min. | 88-375Vdc | continuous operation |
| DC input current | typ. | 4.7A / 1.7A | 110Vdc / 300Vdc, 36V, 13.3A |
| Turn-on voltage | typ. | 73Vdc | steady state value |
| Shut-down voltage | typ. | 57Vdc | steady state value |

Fig. 7-1 Wiring for DC Input

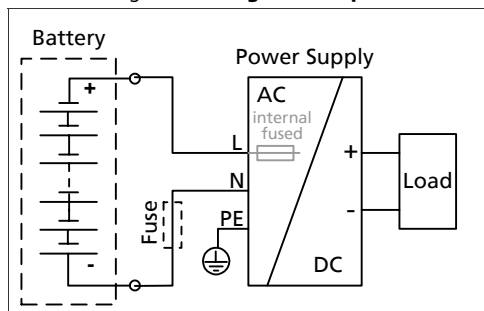

Instructions for DC use:

- Use a battery or similar DC source.
- Connect +pole to L and -pole to N.
- Connect the PE terminal to an earth wire or to the machine ground.

In case the -pole of the battery is not connected to earth, use an appropriate fuse to protect the N terminal.

8. OUTPUT

| | | | |
|--------------------------|------|---------|---|
| Output voltage | nom. | 36V | |
| Adjustment range | min. | 36-42V | guaranteed, multi turn potentiometer at clockwise end position of potentiometer |
| | max. | 45V | |
| Factory setting | | 36.0V | ±0.2%, at full load, cold unit |
| Line regulation | max. | 10mV | 60 to 300Vac |
| Load regulation | max. | 100mV | static value, 0A → 13.3A → 0A |
| Ripple and noise voltage | max. | 100mVpp | 20Hz to 20MHz, 50Ohm |
| Output capacitance | typ. | 4 500µF | |

Continuous power capability

| | | | |
|-----------------------|------|-------|--|
| Output current | nom. | 13.3A | at 36V, see Fig. 8-1 |
| | nom. | 11.4A | at 42V, see Fig. 8-1 |
| Output power | nom. | 480W | 36V, continuous |
| | nom. | 480W | 42V, continuous |
| Short-circuit current | min. | 20A | load impedance 50mOhm, up to 4s before hiccup mode starts, see Fig. 8-1 and Fig. 8-3 |
| | max. | 27A | |

BonusPower[®], short term power capability (up to typ. 4s)

The power supply is designed to support loads with a higher short-term power requirement without damage or shutdown. The short-term duration is hardware controlled by an output power manager. This BonusPower[®] is repeatedly available. Detailed information can be found in chapter 27.1. If the power supply is loaded longer with the BonusPower[®] than shown in the Bonus-time diagram (see Fig. 8-2), the max. output power is automatically reduced to 480W.

If the power requirement is continuously above 480W and the voltage falls below approx. 30V (due to the current regulating mode at overload), the unit shuts-off and makes periodical restart attempts. This behavior is called hiccup mode which is described below. If the voltage is above 30V, the unit continuously delivers current.

Hiccup Mode:

Up to 4s of overloading, the power supply delivers continuous output current. After this, the output power is reduced to nearly zero for approx. 17s before a new start attempt is automatically performed. If the overload has been cleared, the device will operate normally. If the overload still exists, the output current will be delivered for 2 to 4s (depending on the overload) again followed by a 17s rest time. This cycle is repeated as long as the overload exists. See Fig. 8-3. During the off-period a small rest voltage and rest current is present on the output.

| | | | |
|-----------------------|------|-------|---|
| Output current | nom. | 20A | at 36V, see Fig. 8-1 |
| | nom. | 17.1A | at 42V, see Fig. 8-1 |
| Output power | nom. | 720W | 36V, short term |
| | nom. | 720W | 42V, short term |
| Short-circuit current | min. | 20A | load impedance 50mOhm, up to 4s, see Fig. 8-1 |
| | max. | 27A | |
| Bonus time | typ. | 4s | at 36V, 20A, duration until the output voltage dips, see Fig. 8-2 |
| | min | 3.5s | |
| | max. | 4.5s | |

Fig. 8-1 Output voltage vs. output current, typ.

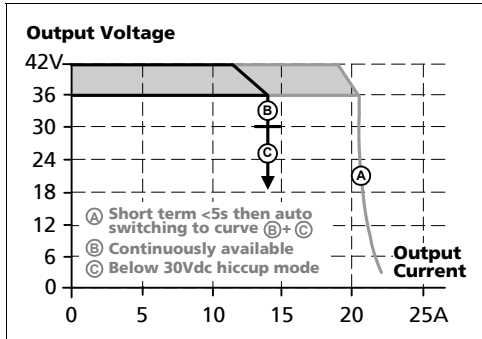

Fig. 8-2 Bonus time vs. output power

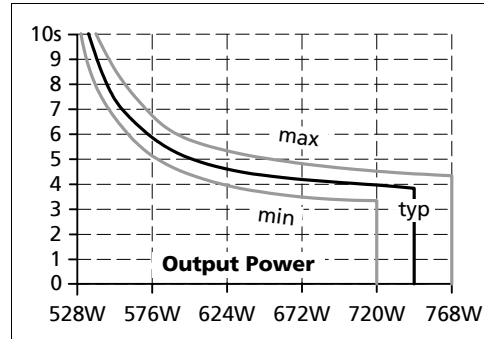
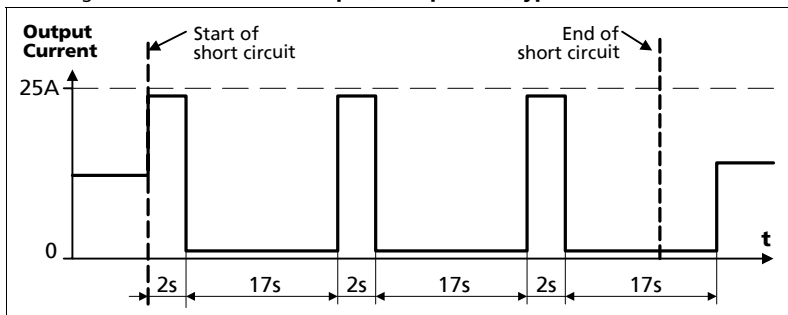

Fig. 8-3 Short-circuit on output, hiccup mode, typical behavior at 36V



The Bonus Power[®] is available as soon as power comes on and immediately after the end of an output short circuit or output overload.

Fig. 8-4 BonusPower[®] after input turn-on

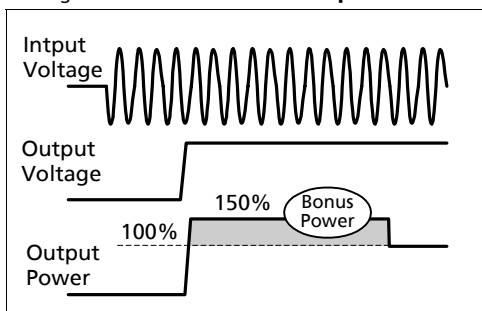
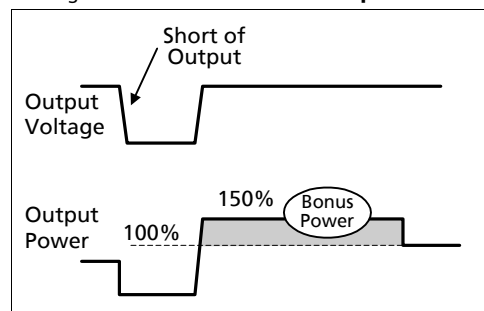

Fig. 8-5 BonusPower[®] after output short



Peak current capability (up to several ms)

The power supply can deliver a peak current which is higher than the specified short term current. This helps to start current demanding loads or to safely operate subsequent circuit breakers.

The extra current is supplied by the output capacitors inside the power supply. During this event, the capacitors will be discharged and causes a voltage dip on the output. Detailed curves can be found in chapter 27.2.

| | | | |
|---------------------------|------|-------------------|-----------------|
| Peak current voltage dips | typ. | from 36V to 30V | at 27A for 20ms |
| | typ. | from 36V to 28V | at 55A for 2ms |
| | typ. | from 36V to 26.6V | at 55A for 5ms |

9. HOLD-UP TIME

| | | AC 100V | AC 120V | AC 230V | |
|--------------|------|---------|---------|---------|--------------------------|
| Hold-up Time | typ. | 32ms | 32ms | 51ms | 13.3A, 36V, see Fig. 9-1 |
| | typ. | 64ms | 64ms | 99ms | 6.7A, 36V, see Fig. 9-1 |

Fig. 9-1 Hold-up time vs. input voltage

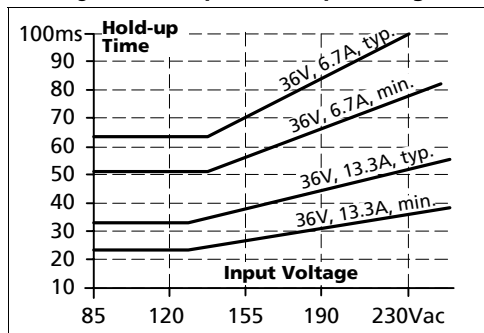
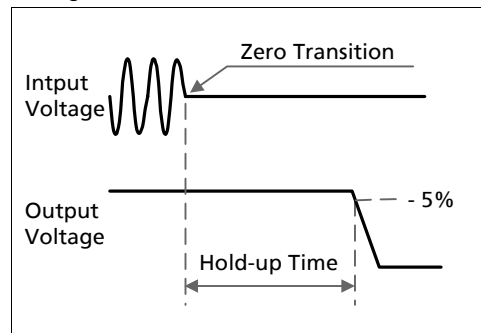

Fig. 9-2 Shut-down behavior, definitions



10. DC-OK RELAY CONTACT

This feature monitors the output voltage, which is produced by the power supply itself. It is independent of a backed voltage from a unit which is connected in parallel to the power supply output.

| | | | |
|-------------------|---|----------------------------------|-----------------------|
| Contact closes | As soon as the output voltage reaches the adjusted output voltage. | | |
| Contact opens | As soon as the output voltage dips more than 10% below the adjusted output voltage. Short dips will be extended to a signal length of 250ms. Dips shorter than 1ms will be ignored. | | |
| Contact re-closes | As soon as the output voltage exceeds 90% of the adjusted voltage. | | |
| Contact ratings | max | 60Vdc 0.3A, 30Vdc 1A, 30Vac 0.5A | resistive load |
| | min | 1mA at 5Vdc | min. permissible load |
| Isolation voltage | See dielectric strength table in section 20 | | |

Fig. 10-1 DC-ok relay contact behavior

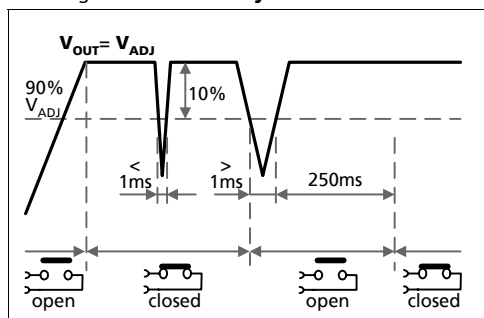

Note:

The DC-ok feature requires that the output voltage reaches the nominal (=adjusted) level after turn-on in order to function according to specification. If this level cannot be achieved, the overload LED will be on and the DC-ok contact will be open. The overload signal will only shut off as soon as the adjusted voltage is reached. This is an important condition to consider particularly, if the load is a battery, the power supply is used in parallel or the power supply is used for N+1 redundant systems.

11. EFFICIENCY AND POWER LOSSES

| | | AC 100V | AC 120V | AC 230V | |
|--------------|------|----------------|----------------|----------------|------------|
| Efficiency | typ. | 91.7% | 92.5% | 94.0% | 13.3A, 36V |
| Power losses | typ. | 43.4W | 38.9W | 30.6W | 13.3A, 36V |
| | typ. | 9.0W | 9.2W | 10.0W | 0A |

Fig. 11-1 Efficiency vs. output current at 36V

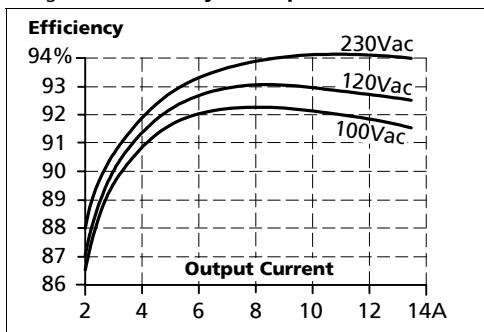

Fig. 11-2 Losses vs. output current at 36V

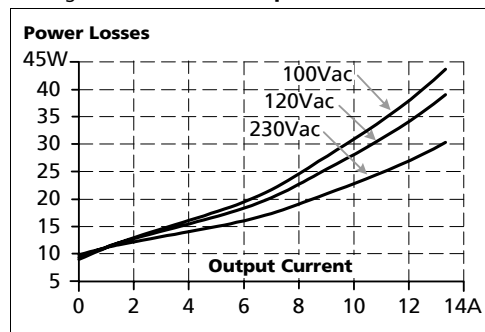

Fig. 11-3 Efficiency vs. input voltage 36V, 13.3A

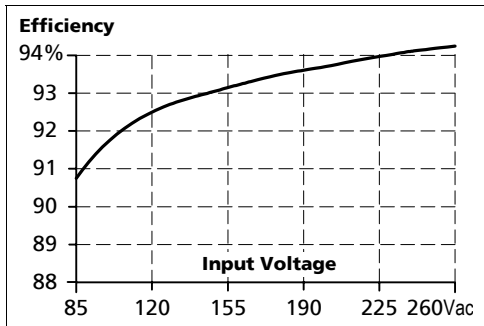
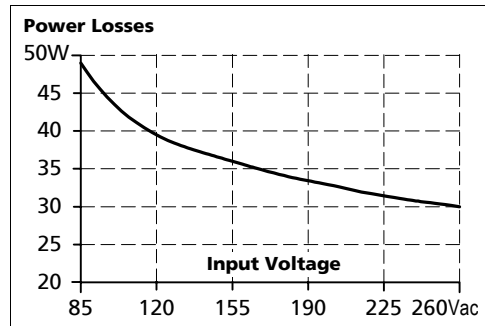
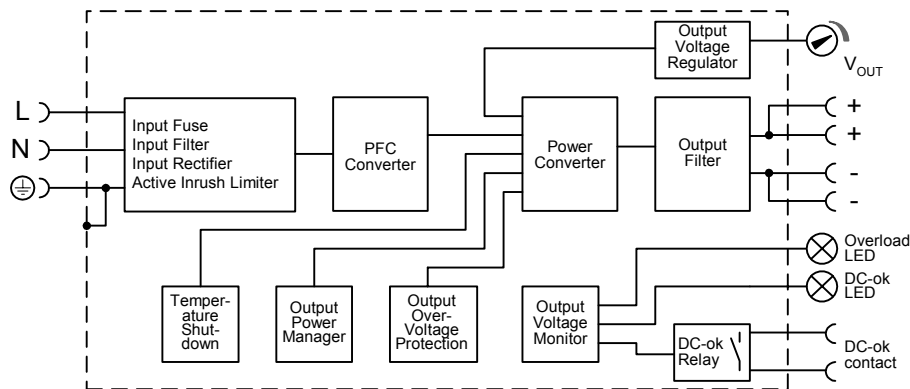

Fig. 11-4 Losses vs. input voltage, 36V, 13.3A



12. FUNCTIONAL DIAGRAM

Fig. 12-1 Functional diagram



13. FRONT SIDE AND USER ELEMENTS

Fig. 13-1 Front side

Output Terminals

Quick-connect spring-clamp terminals, no tools required
 + Positive output pole
 - Negative output pole
 Dual pins per pole

DC ok Relay contact (NO-contact)

480W Continuous power / 720W Peak power

Input Terminals

Quick-connect spring-clamp terminals, no tools required
 N ... Neutral input
 L ... Line (hot) input
 PE ... PE (Protective Earth)
 See chapter 14 "Terminals and Wiring" to choose appropriate wire gauges

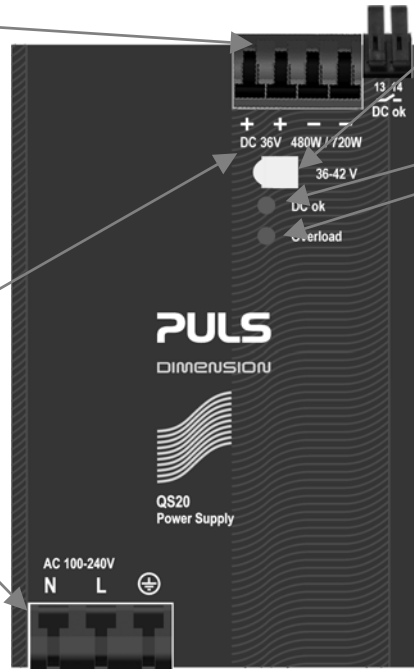

Output voltage potentiometer

(multi turn potentiometer)
 Open the flap to tune the output voltage.
 Factory setting: 36.0V

DC-ok LED (green)
Overload LED (red)

| | Overload LED | DC-ok LED | DC-ok contact |
|--|--------------|-----------|---------------|
| Normal mode | OFF | ON | Closed |
| BonusPower® mode | OFF | ON | Closed |
| Overload ($V_{OUT} > 90\%$) | OFF | ON | Closed |
| Overload ($V_{OUT} < 90\%$) | *) | OFF | Open |
| Short-circuit ($V_{OUT} = \text{ca. } 0V$) | *) | OFF | Open |
| Over-temperature | *) | OFF | Open |
| No input power | OFF | OFF | Open |

DC-ok LED and DC-ok contact function synchronized

*) Up to 4s of overloading, the power supply delivers continuous output current. After this, the output power is reduced to nearly zero for approx. 17s before a new start attempt is automatically performed. If the overload has been cleared, the device will operate normally. If the overload still exists, the output current will be delivered for 2 to 4s (depending on the overload) again followed by a 17s rest time. This cycle is repeated as long as the overload exists. The red overload LED is permanently on when the overload current is continuously flowing. During the 17s rest period, the red LED is flashing with a frequency of approx. 1.3Hz.

14. TERMINALS AND WIRING

| | |
|----------------|---|
| Type | Bi-stable, quick-connect spring clamp terminals. IP20 Finger safe construction. Suitable for field- and factory installation. Shipped in open position. |
| Ferrules | allowed, but not required |
| Pull-out force | 10AWG:80N, 12AWG:60N, 14AWG:50N, 16AWG:40N (according to UL486E) |

| | Power terminals | DC-OK-Signal terminals |
|-----------------------|----------------------|------------------------|
| Solid wire | 0.5-6mm ² | 0.3-4mm ² |
| Stranded wire | 0.5-4mm ² | 0.3-2.5mm ² |
| American wire gauge | 20-10 AWG | 26-12 AWG |
| Wire stripping length | 10mm / 0.4inch | 6mm / 0.25inch |

Fig. 14-1 Connecting a wire

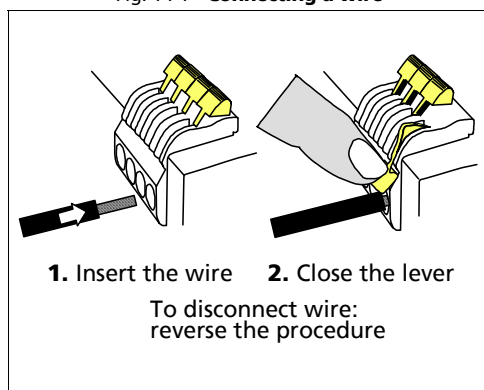

Instructions:

- a) Use appropriate copper cables that are designed for an operating temperature of: 60°C for ambient up to 45°C and 75°C for ambient up to 60°C minimum.
- b) Follow national installation codes and installation regulations!
- c) Ensure that all strands of a stranded wire enter the terminal connection!
- d) Up to two stranded wires with the same cross section are permitted in one connection point (except PE wire).
- e) Do not use the unit without PE connection.

15. RELIABILITY

| | | AC 100V | AC 120V | AC 230V | |
|--------------------------|------|----------|------------|------------|--------------------------------------|
| Lifetime expectancy | min. | 53 000h | 61 000h | 84 000h | 40°C, 36V, 13.3A |
| | min. | 118 000h | 127 000h | 146 000h | 40°C, 36V, 6.7A (=50% load) |
| | min. | 149 000h | > 15 years | > 15 years | 25°C, 36V, 13.3A |
| MTBF SN 29500, IEC 61709 | | 407 000h | 441 000h | 469 000h | 40°C, 36V, 13.3A |
| | | 749 000h | 799 000h | 840 000h | 25°C, 36V, 13.3A |
| MTBF MIL HDBK 217F | | 204 000h | 215 000h | 229 000h | 40°C, 36V, 13.3A, Ground Benign GB40 |
| | | 273 000h | 288 000h | 308 000h | 25°C, 36V, 13.3A, Ground Benign GB25 |

The **Lifetime expectancy** shown in the table indicates the operating hours (service life) and is determined by the lifetime expectancy of the built-in electrolytic capacitors.

Lifetime expectancy is specified in operational hours. Lifetime expectancy is calculated according to the capacitor's manufacturer specification. The prediction model allows a calculation of up to 15 years from date of shipment.

MTBF stands for **Mean Time Between Failure**, which is calculated according to statistical device failures, and indicates reliability of a device. It is the statistical representation of the likelihood of the unit to fail and does not necessarily represent the life of a product.

16. EMC

The power supply is suitable for applications in industrial environment as well as in residential, commercial and light industry environment without any restrictions. CE mark is in conformance with EMC guideline 89/336/EEC and 93/68/EEC and the low-voltage directive (LVD) 73/23/EWG. A detailed EMC Report is available upon request

| EMC Immunity | EN 61000-6-1 EN 61000-6-2 | | Generic standards | |
|--------------------------|---------------------------|------------------------|-------------------|-------------|
| Electrostatic discharge | EN 61000-4-2 | Contact discharge | 8kV | Criterion A |
| | | Air discharge | 15kV | Criterion A |
| Electromagnetic RF field | EN 61000-4-3 | 80MHz-1GHz | 10V/m | Criterion A |
| Fast transients (Burst) | EN 61000-4-4 | Input lines | 4kV | Criterion A |
| | | Output lines | 2kV | Criterion A |
| Surge voltage on input | EN 61000-4-5 | L → N | 2kV | Criterion A |
| | | N / L → PE | 4kV | Criterion A |
| Surge voltage on output | EN 61000-4-5 | + → - | 500V | Criterion A |
| | | + / - → PE | 500V | Criterion A |
| Conducted disturbance | EN 61000-4-6 | 0.15-80MHz | 10V | Criterion A |
| Mains voltage dips | EN 61000-4-11 | 0% of 100Vac | 0Vac, 20ms | Criterion A |
| | | 40% of 100Vac | 40Vac, 200ms | Criterion C |
| | | 70% of 100Vac | 70Vac, 500ms | Criterion C |
| Voltage interruptions | EN 61000-4-11 | | 0Vac, 5000ms | Criterion C |
| Voltage sags | SEMI F47 0200 | | 96Vac, 1000ms | Criterion A |
| | | | 84Vac, 500ms | Criterion A |
| | | | 60Vac, 200ms | Criterion A |
| Input voltage swells | PULS internal standard | | 300Vac, 500ms | Criterion A |
| Powerful transients | VDE 0160 | over entire load range | 750V, 1.3ms | Criterion C |

Criteria:

A: Power supply shows normal operation behavior within the defined limits.

C: Temporary loss of function is possible. Power supply might shut-down and restarts by itself. No damages or hazards for the power supply occur.

| EMC Emission | Generic standards: EN 61000-6-3 and EN 61000-6-4 | |
|-------------------------------|---|-----------------------|
| Conducted emission | EN 55011, EN 55022, FCC Part 15, CISPR 11, CISPR 22 EN 55022 | Class B, input lines |
| | | Class B, output lines |
| Radiated emission | EN 55011, EN 55022 | Class B |
| Harmonic input current | EN 61000-3-2 | Fulfilled, active PFC |
| Voltage fluctuations, flicker | EN 61000-3-3 | Fulfilled |

This device complies with FCC Part 15 rules.

Operation is subjected to following two conditions: (1) this device may not cause harmful interference, and (2) this device must accept any interference received, including interference that may cause undesired operation.

| Switching Frequencies | The power supply has four converters with four different switching frequencies included. One is nearly constant. The others are input voltage and load dependent. | |
|------------------------------|---|---|
| Switching frequency 1 | 100kHz | Resonant converter, nearly constant |
| Switching frequency 2 | 110kHz to 500kHz | Boost converter, input voltage and load dependent |
| Switching frequency 3 | 73kHz to 114kHz | PFC converter, input voltage and load dependent |
| Switching frequency 4 | 35-45kHz | Aux. Converter, input voltage and load dependent |

17. ENVIRONMENT

| | | |
|---------------------------------|--|--|
| Operational temperature | -25°C to +70°C (-13°F to 158°F) | reduce output power above +60°C |
| Output de-rating | 12W/°C | 60-70°C (140°F to 158°F), see Fig. 17-1 |
| Storage temperature | -40 to +85°C (-40°F to 185°F) | storage and transportation |
| Humidity | 5 to 95% r.H. | IEC 60068-2-30 Do not energize while condensation is present |
| Vibration sinusoidal | 2-17.8Hz: ±1.6mm; 17.8-500Hz: 2g 2 hours / axis | IEC 60068-2-6 |
| Vibration random | 0.5m ² (s ³) 2 hours / axis | IEC 60068-2-64 |
| Shock | 30g 6ms, 20g 11ms 3 bumps / direction, 18 bumps in total | IEC 60068-2-27 |
| Altitude | 0 to 6000m (0 to 20 000ft) | Reduce output power or ambient temperature above 2000m sea level. |
| Output de-rating (for altitude) | 30W/1000m or 5°C/1000m | above 2000m (6500ft), see Fig. 17-2 |
| Over-voltage category | III | EN 50178, altitudes up to 2000m |
| | II | Altitudes from 2000m to 6000m |
| Degree of pollution | 2 | EN 50178, not conductive |

Fig. 17-1 Output current vs. ambient temp.,

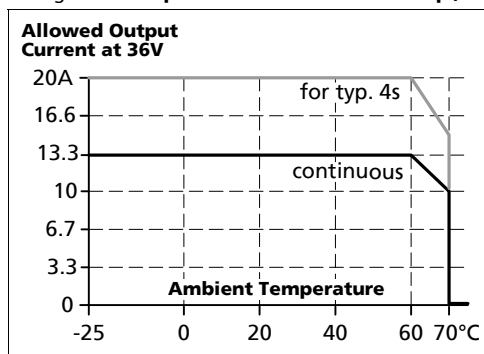
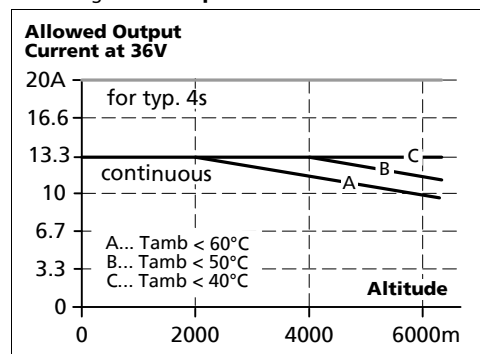

Fig. 17-2 Output current vs. altitude



The ambient temperature is defined as the air temperature 2cm below the unit.

18. PROTECTION FEATURES

| | | |
|--------------------------------|---|---|
| Output protection | Electronically protected against overload, no-load and short-circuits | |
| Output over-voltage protection | typ. 50Vdc max. 53Vdc | In case of an internal power supply defect, a redundant circuitry limits the maximum output voltage. The output shuts down and automatically attempts to restart. |
| Output over-current protection | Electronically limited | See Fig. 8-1 |
| Degree of protection | IP 20 | EN/IEC 60529 |
| Penetration protection | > 3.5mm / >5mm | top side / bottom side, e.g. screws, small parts |
| Over-temperature protection | yes | output shut-down with automatic restart |
| Input transient protection | MOV (Metal Oxide Varistor) | |
| Internal input fuse | T10A H.B.C. | not user replaceable |

Note: In case of a protection event, audible noise may occur.

19. SAFETY

| | | |
|---------------------------------|---|--|
| Input / output separation | SELV PELV double or reinforced insulation | IEC/EN 60950-1 EN 60204-1, EN 50178, IEC 60364-4-41 |
| Class of protection | I | PE (Protective Earth) connection required |
| Isolation resistance | > 5MΩ | input to output, 500Vdc |
| PE resistance | < 0.1Ω | between housing and PE terminal |
| Touch current (leakage current) | typ. 0.23mA typ. 0.34mA typ. 0.58mA < 0.31mA < 0.45mA < 0.80mA | 100Vac, 50Hz, TN mains 120Vac, 60Hz, TN mains 230Vac, 50Hz, TN mains 110Vac, 50Hz, TN mains 132Vac, 60Hz, TN mains 264Vac, 50Hz, TN mains |

20. DIELECTRIC STRENGTH

Fig. 20-1 Dielectric strength

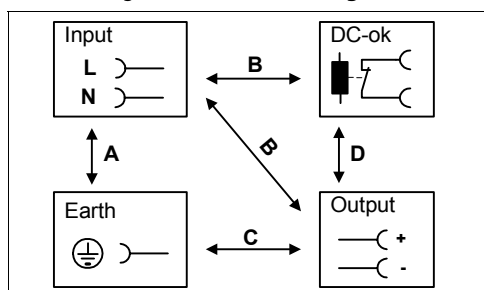

| | | A | B | C | D |
|--------------|-----|---------|---------|--------|--------|
| Type test | 60s | 2500Vac | 3000Vac | 500Vac | 500Vac |
| Factory test | 5s | 2500Vac | 2500Vac | 500Vac | 500Vac |
| Field test | 5s | 2000Vac | 2000Vac | 500Vac | 500Vac |

Type tests and factory tests:

Conducted by the manufacturer. Do not repeat test in field!



Rules for field test:

Use appropriate test equipment which applies the voltage with a slow ramp! Connect L and N together as well as all output poles.

The output voltage is floating and has no ohmic connection to ground.

To fulfill the PELV requirements according to EN60204-1 § 6.4.1, we recommend that either the + pole, the - pole or any other part of the output circuit shall be connected to the protective earth system. This helps to avoid situations in which a load starts unexpectedly or can not be switched off any more when unnoticed earth faults occur.

21. APPROVALS

| | | |
|----------------|---|---|
| IEC 60950-1 |  | CB Scheme, Information Technology Equipment |
| UL 508 |  | LISTED E198865 Industrial Control Equipment |
| UL 60950-1 |  | RECOGNIZED E137006 recognized for the use in U.S.A. (UL 60950-1) and Canada (C22.2 No. 60950) Information Technology Equipment, Level 5 |
| Marine pending |  | GL (Germanischer Lloyd) classified and ABS (American Bureau for Shipping) PDA for marine and offshore applications. Environmental category: C, EMC2 |

22. FULFILLED STANDARDS

| | |
|---------------------|---|
| EN 61558-2-17 | Safety of Power Transformers |
| EN/IEC 60204-1 | Safety of Electrical Equipment of Machines |
| EN/IEC 61131-2 | Programmable Controllers |
| EN 50178, IEC 62103 | Electronic Equipment in Power Installations |
| SEMI F47 | SEMI F47-0200, Ride-through compliance for semiconductor industry. Full SEMI range compliance (Input: 120Vac or 208Vac, output: 480W) |
| UL1604 | Hazardous Location Class I Div 2 T3C Groups A,B,C,D |

23. USED SUBSTANCES

The unit does not release any silicone and is suitable for the use in paint shops.

The unit conforms to the RoHS directive 2002/96/EC

Electrolytic capacitors included in this unit do not use electrolytes such as Quaternary Ammonium Salt Systems.

Plastic housings and other molded plastic materials are free of halogens.

The production material within our production does not include following toxic chemicals: Polychlorized Biphenyl (PCB), Polychlorized Terphenyl (PCT), Pentachlorophenol (PCP), Polychlorinated naphthalene (PCN), Polybrom Biphenyl (PBB), Polybrom Biphenyl-oxyd (PBO), Polybrominated Diphenylether (PBDE), Polychlorinated Diphenylether (PCDE), Polydibromophenyl Oxyd (PBDO), Cadmium, Asbest, Mercury, Silicia

24. PHYSICAL DIMENSIONS AND WEIGHT

| | |
|----------|---|
| Weight | 1200g / 2.65lb |
| DIN-Rail | Use 35mm DIN-rails according to EN 60715 or EN 50022 with a height of 7.5 or 15mm. The DIN-rail height must be added to the depth (127mm) to calculate the total required installation depth. |

Electronic files with mechanical data can be downloaded at www.pulspower.com

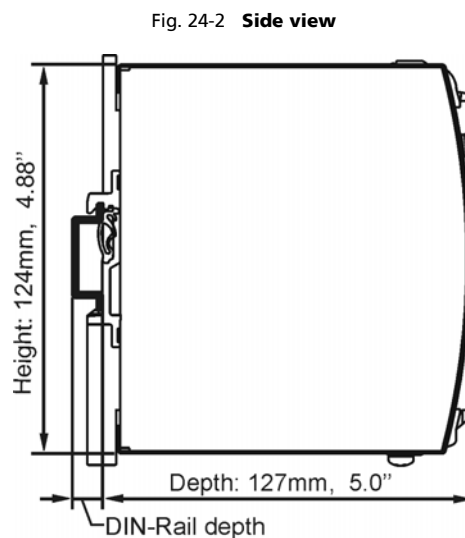
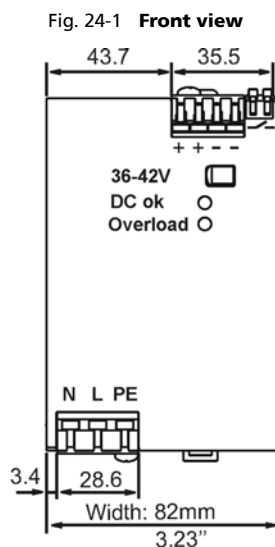

25. INSTALLATION AND OPERATION INSTRUCTIONS

Mounting and installation:

Output terminal must be located on top and input terminal on the bottom. For other orientations see section 27.14. An appropriate electrical and fire end-product enclosure needs to be considered in the end use application.

Cooling:

Convection cooled, no forced cooling required. Do not cover ventilation grid (e.g. cable conduits) by more than 30%!

Installation clearances:

40mm on top, 20mm on the bottom, 5mm on the left and right side are recommended when loaded permanently with full power. In case the adjacent device is a heat source, 15mm clearance is recommended.

Risk of electrical shock, fire, personal injury or death!

Do not use the unit without proper earth connection (Protective Earth). Use the pin on the terminal block for earth connection and not one of the screws on the housing.

Turn power off before working on the power supply. Protect against inadvertent re-powering.

Make sure the wiring is correct by following all local and national codes.

Do not open, modify or repair the unit.

Use caution to prevent any foreign objects from entering into the housing.

Do not use in wet locations or in areas where moisture or condensation can be expected.

Service parts:

The unit does not contain any serviceable parts. The tripping of an internal fuse is caused by an internal defect. If damage or malfunctioning should occur during operation, immediately turn power off and send unit to factory for inspection!

26. ACCESSORY

ZM1.WALL Wall mounting bracket

This bracket is used to mount Dimension units onto a flat surface without utilizing a DIN-Rail. The two aluminum brackets and the black plastic slider of the unit have to be detached, so that the two steel brackets can be mounted.

Fig. 26-1 ZM1.WALL Wall Mounting Bracket

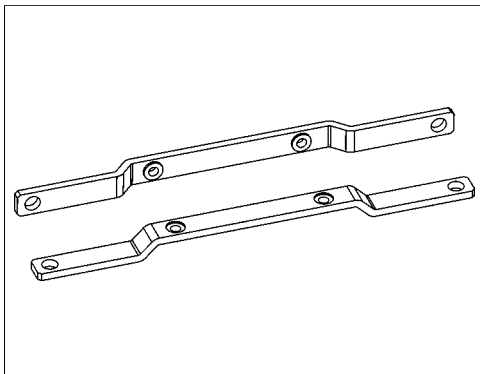
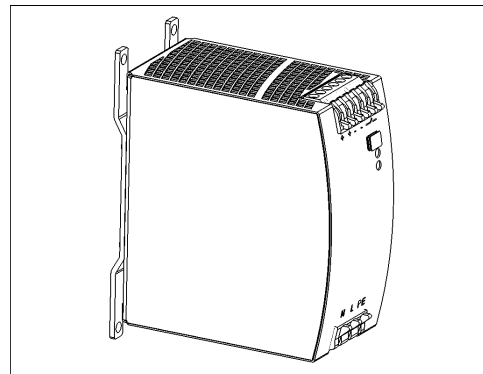

Fig. 26-2 Assembled Wall Mounting Bracket



ZM15.SIDE Side mounting bracket

This bracket is used to mount Dimension units sideways with or without utilizing a DIN-Rail. The two aluminum brackets and the black plastic slider of the unit have to be detached, so that the steel brackets can be mounted.

For sideways DIN-rail mounting, the removed aluminum brackets and the black plastic slider need to be mounted on the steel bracket.

Fig. 26-3 Side Mounting Bracket

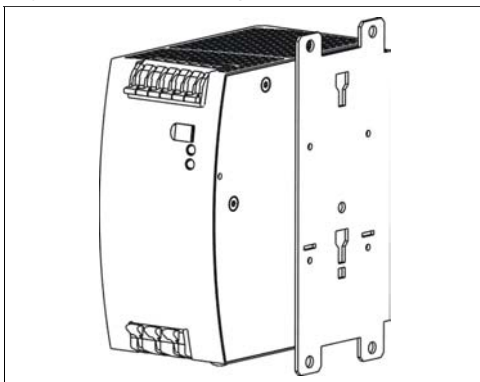
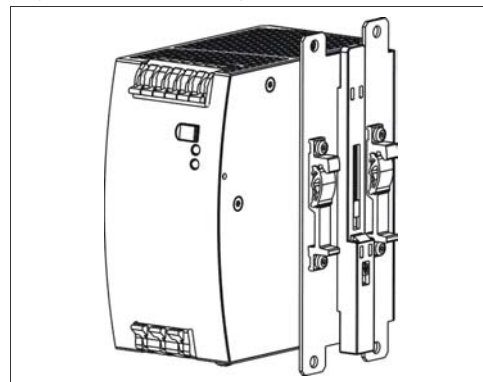

Fig. 26-4 Side Mounting with DIN-rail brackets



Please note: Symbolic drawing, picture show a different model

27. APPLICATION NOTES

27.1. REPETITIVE PULSE LOADING

Typically, a load current is not constant. It varies over time. For pulse load compatibility, following rules must be met:

- The pulse power demand must be below 150% of the nominal power.
- The duration of the pulse power must be shorter than the allowed Bonus Time. (see output section)
- The average (R.M.S.) output current must be below the specified continuous output current. If the R.M.S. current is higher, the unit will respond with a thermal shut-down after a while. Use the max. duty cycle curve (Fig. 27-2) to check if the average output current is below the nominal current.
- For altitudes higher than 2000m reduce the pulse loading (30W/1000m) or the ambient temperature (5°C/1000m)

Fig. 27-1 Repetitive pulse loads, definitions

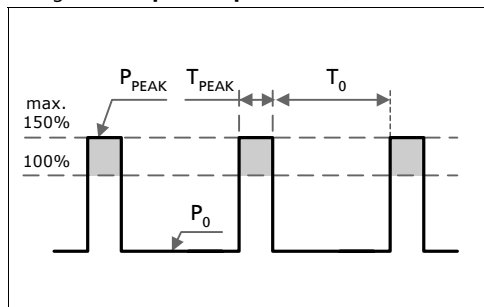

- P₀** Base load (W)
- P_{PEAK}** Pulse load (above 100%)
- T₀** Duration between pulses (s)
- T_{PEAK}** Pulse duration (s)

Fig. 27-2 Max. Duty Cycle Curve

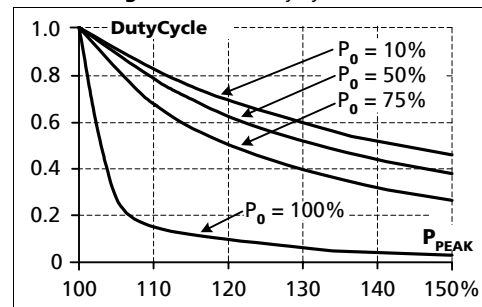

$$\text{DutyCycle} = \frac{T_{\text{peak}}}{T_{\text{peak}} + T_0}$$

$$T_0 = \frac{T_{\text{peak}} - (\text{DutyCycle} \times T_{\text{peak}})}{\text{DutyCycle}}$$

Utilizing the Max. Duty Cycle Curve:

Example to determine the repetition rate of pulses without dipping of the output voltage:

Parameters of application:

Pulse length is T_{PEAK} = 1s

Steady state load P₀=120W
(= 50% of I_{RATED})

Peak load P_{PEAK} = 360W
(= 150% of I_{RATED})

Determining the repetition rate:

- make a vertical line at P_{PEAK} = 150%
- make a horizontal line where the vertical line crosses the P₀ = 50% curve
- Read the Max. Duty Cycle from the Duty Cycle-axis (= 0.37)
- Calculate the min. pause (base load) length T₀ :

$$T_0 = \frac{T_{\text{peak}} - (\text{DutyCycle} \times T_{\text{peak}})}{\text{DutyCycle}} = \frac{1\text{s} - (0.37 \times 1\text{s})}{0.37} = \mathbf{1.7\text{s}}$$

- Pulse length = 1s, min. pause length = 1.7s
- Max. repetition rate = pulse length + pause length = **2.7s**

More examples for pulse load compatibility:

| P _{PEAK} | P ₀ | T _{PEAK} | T ₀ |
|-------------------|----------------|-------------------|----------------|
| 720W | 480W | 1s | >25s |
| 720W | 0W | 1s | >1.3s |
| 600W | 240W | 1s | > 0.75s |

| P _{PEAK} | P ₀ | T _{PEAK} | T ₀ |
|-------------------|----------------|-------------------|----------------|
| 720W | 240W | 0.1s | >0.16s |
| 720W | 240W | 1s | >1.6s |
| 720W | 240W | 3s | >4.9s |

27.2. PEAK CURRENT CAPABILITY

Solenoids, contactors and pneumatic modules often have a steady state coil and a pick-up coil. The inrush current demand of the pick-up coil is several times higher than the steady state current and usually exceeds the nominal output current (including the Bonus Power®). The same situation applies, when starting a capacitive load.

Branch circuits are often protected with circuit breakers or fuses. In case of a short or an overload in the branch circuit, the fuse needs a certain amount of over-current to trip or to blow. The peak current capability ensures the safe operation of subsequent circuit breakers.

Assuming the input voltage is turned on before such an event, the built-in large sized output capacitors inside the power supply can deliver extra current. Discharging this capacitor causes a voltage dip on the output. The following two examples show typical voltage dips:

Fig. 27-3 Peak load 27A for 50ms, typ.

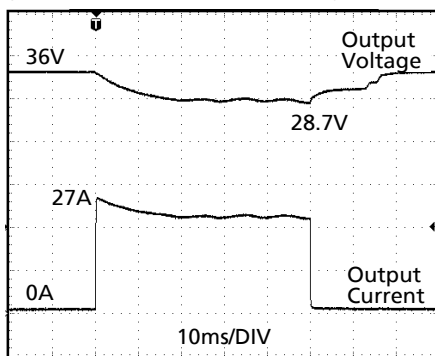

Peak load 27A (resistive) for 50ms
Output voltage dips from 36V to 29.0V.

Fig. 27-4 Peak load 55A for 5ms, typ.

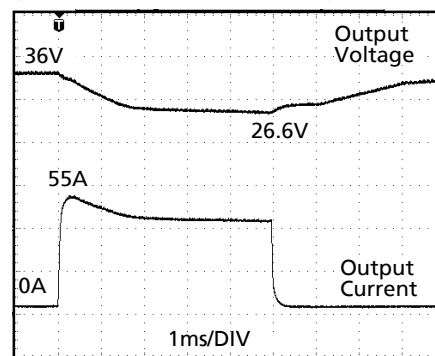

Peak load 55A (nearly resistive) for 5ms
Output voltage dips from 36V to 26.6V.

Please note: The DC-OK relay triggers when the voltage dips more than 10% for longer than 1ms.

27.3. BACK-FEEDING LOADS

Loads such as decelerating motors and inductors can feed voltage back to the power supply. This feature is also called return voltage immunity or resistance against Back- E.M.F. (Electro Magnetic Force).

This power supply is resistant and does not show malfunctioning when a load feeds back voltage to the power supply. It does not matter, whether the power supply is on or off.

The maximum allowed feed back voltage is 48Vdc. The absorbing energy can be calculated according to the built-in large sized output capacitor which is specified in chapter 8. If the feed back voltage gets higher than 48Vdc, the power supply responds with a shut-down and a subsequent start-up attempt.

27.4. CHARGING OF BATTERIES

The power supply can be used for float-charging of lead-acid or maintenance free 36V VRLA batteries.

Instructions for charging batteries:

- Set the output voltage, at disconnected load, very precisely to the end-of-charge voltage according to the expected battery temperature.

| | | | | |
|-----------------------|-------|-------|-------|-------|
| End-of-charge voltage | 41.7V | 41.3V | 40.7V | 40.2V |
| Battery temperature | 10°C | 20°C | 30°C | 40°C |

- Use a 20A circuit breaker (or blocking diode) between the power supply and the battery.
- Ensure that the output current of the power supply is below the allowed charging current of the battery.
- Use only matched batteries when putting 12V types in series.
- The return current to the power supply is typ. 9mA at 38Vdc when the power supply is switched off.

27.5. OUTPUT CIRCUIT BREAKERS

Standard miniature circuit breakers (MCBs) can be used for branch protection. Ensure that the MCB is rated for DC voltage, too. The following tests show which circuit breakers the power supply typically trips.

Circuit breakers have huge tolerances in their tripping behavior. Therefore, these typical tests can only be used as a recommendation or for comparing two different power supplies. Furthermore, the loop impedance has a major influence on whether a breaker trips or not. Two tests were performed, representing typical situations:

Test 1: Short circuit with S1 on the power supply end of the cable (loop impedance approx. 20mOhm)

Fig. 27-5 Branch protectors, test circuit 1

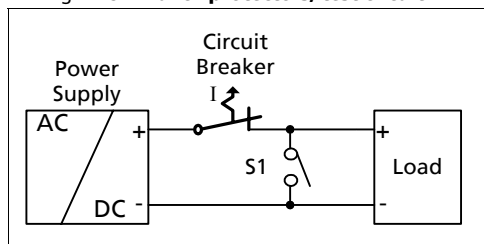

Parameters:

Input voltage: 230Vac, load current: 0A
Tripping time shorter than 5s.

The following circuit breaker tripped during the test:

- A- or Z- Characteristic:** equal or smaller 20A*)
- B- Characteristic:** equal or smaller 16A*)
- C- Characteristic:** equal or smaller 13A*)

Test 2: Short circuit with S1 on the load end (additional impedance included; represents longer load wire length).

Fig. 27-6 Branch protectors, test circuit 2

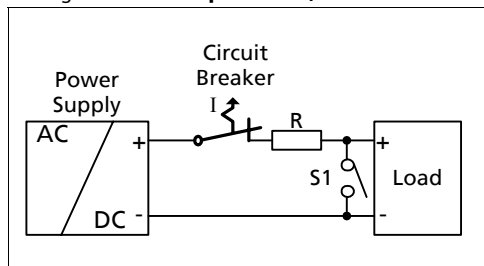

Parameters:

Input voltage: 230Vac, load current: 0A
Tripping time shorter than 5s.

The following circuit breaker tripped during the test:

- A- or Z- Characteristic:** $\leq 20A$ and $R < 82mOhm^*$)
- B- Characteristic:** $\leq 10A$ and $R < 120mOhm^*$)
- C- Characteristic:** $\leq 6A$ and $R < 180mOhm^*$)

What does this resistance mean in wire length?

| | 0.5mm ² | 0.7mm ² | 1.0mm ² | 1.5mm ² | 2.5mm ² | 4.0mm ² |
|----------------|--------------------|--------------------|--------------------|--------------------|--------------------|--------------------|
| 82mOhm | 2.3m | 3.2m | 4.6m | 6.9m | 11.4m | 18.3m |
| 120mOhm | 3.3m | 4.7m | 6.7m | 10.0m | 16.7m | 26.7m |
| 180mOhm | 5.0m | 7.0m | 10.0m | 15.0m | 25.1m | 40.1m |

*) A list of the circuit breakers under test is available on request.

Example:

Which wire gauge must be used to trip a C-Characteristic circuit breaker with a rating of 6A? The load wire length is 21m.

Answer: A 6A C-Characteristic circuit breaker requires a loop impedance of less than 180mOhm (test results). The wire length table shows that up to 25.1m wire with a cross section of 2.5mm² are below 180mOhm. A wire not smaller than 2.5mm² shall be used.

27.6. EXTERNAL INPUT PROTECTION

The unit is tested and approved for branch circuits up to 20A. External protection is only required, if the supplying branch has an ampacity greater than this. In some countries local regulations might apply. Check also local codes and local requirements.

If an external fuse is necessary or utilized, a minimum value is required to avoid undesired tripping of the fuse.

| | | B-Characteristic | C-Characteristic |
|----------|------|------------------|------------------|
| Ampacity | max. | 20A | 20A |
| | min. | 10A | 10A |

27.7. PARALLEL USE TO INCREASE OUTPUT POWER

Power supplies can be paralleled to increase the output power.

Fig. 27-7 Schematic for parallel operation

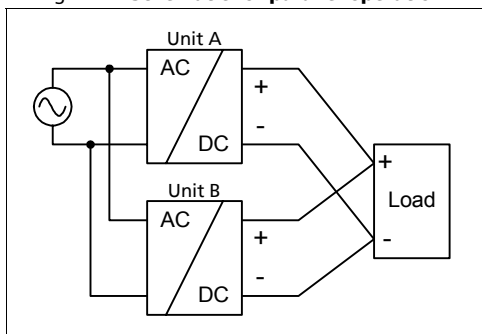

Instructions for parallel use:

- Use only power supplies from the same series (Q-Series).
- Adjust the output voltages of all power supplies to approximately the same value ($\pm 750\text{mV}$). Otherwise, the DC-ok signal might not work properly.
- A fuse (or diode) on the output is only required if more than three units are connected in parallel.
- Do not continuously load the terminals with more than 25A. Follow wiring instructions according to chapter 27.9
- Keep an installation clearance of 15mm (left/right) between two power supplies and avoid installing the power supplies on top of each other.

27.8. PARALLEL USE FOR REDUNDANCY

Power supplies can be paralleled for redundancy to gain a higher system availability. Redundant systems require a certain amount of extra power to support the load in case one power supply unit fails. The simplest way is to put two Q-Series power supplies in parallel. This is called a 1+1 redundancy. In case one power supply unit fails, the other one is automatically able to support the load current without any interruption. Redundant systems for a higher power demand are usually built in a N+1 method. E.g. Five power supplies, each rated for 10A are paralleled to build a 40A redundant system.

Please note: This simple way to build a redundant system does not cover failures such as an internal short circuit in the secondary side of the power supply. In such a - virtually nearly impossible - case, the defect unit becomes a load for the other power supplies and the output voltage can not be maintained any more. This can only be avoided by utilizing decoupling diodes which are included in the decoupling module YR2.DIODE. (One Diode module per power supply)

Recommendations for building redundant power systems:

- Use separate input fuses for each power supply.
- Monitor the individual power supply units. A DC-ok LED and a DC-ok contact is already included in the units. This feature reports a faulty unit.
- When possible, connect each power supply to different phases or circuits.
- It is desirable to set the output voltages of all power supplies to the same value to avoid a false DC-ok signal.

27.9. DAISY-CHAINING OF OUTPUTS

Daisy chaining (jumping from one power supply output to the next) is allowed as long as the max. current through one terminal pin does not continuously exceed 20A. If the current is higher, use a separate distribution terminal.

Fig. 27-8 **Daisy chaining of outputs**

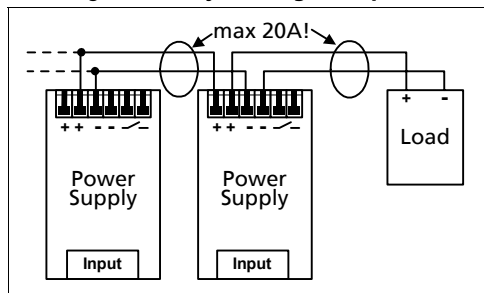
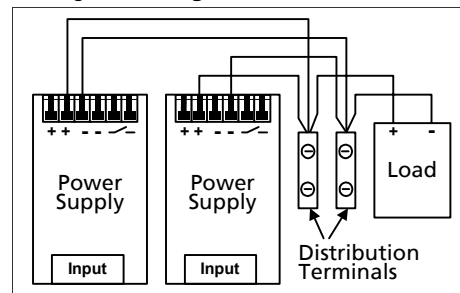

Fig. 27-9 **Using distribution terminals**



27.10. SERIES OPERATION

The power supply can be put in series to increase the output voltage.

Fig. 27-10 **Schematic for series operation**

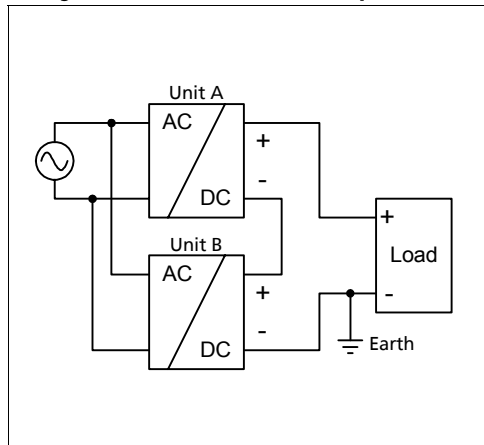

Instructions for use in series:

- It is possible to connect as many units in series as needed, providing the sum of the output voltage does not exceed 150Vdc.
- Voltages with a potential above 60Vdc are not SELV any more and can be dangerous. Such voltages must be installed with a protection against touching.
- For serial operation use power supplies of the same type.
- Earthing of the output is required when the sum of the output voltage is above 60Vdc.
- Keep an installation clearance of 15mm (left/right) between two power supplies and avoid installing the power supplies on top of each other.

Note: Avoid return voltage (e.g. from a decelerating motor or battery) which is applied to the output terminals.

27.11. INDUCTIVE AND CAPACITIVE LOADS

The unit is designed to supply any kind of load, including unlimited capacitive and inductive loads.

27.12. OPERATION ON TWO PHASES

Fig. 27-11 Schematic for two phase operation

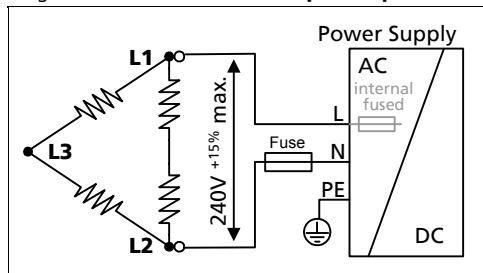

Instructions for two phase operation:

- a) A phase to phase connection is allowed as long as the supplying voltage is below 240V^{+15%}.
- b) Use a fuse or a circuit breaker to protect the N input. The N input is internally not protected and is in this case connected to a hot wire.

Appropriate fuses or circuit breakers are specified in section 27.6 "External Input Protection".

27.13. USE IN A TIGHTLY SEALED ENCLOSURE

When the power supply is installed in a tightly sealed enclosure, the temperature inside the enclosure will be higher than outside. The inside temperature defines the ambient temperature for the power supply.

Results from such an installation:

Power supply is placed in the middle of the box, no other heat producer inside the box

| | |
|--------------------------------|---|
| Enclosure: | Rittal Type IP66 Box PK 9522 100, plastic, 254x180x165mm |
| Load: | 36V, 10.6A; (=80%) load is placed outside the box |
| Input: | 230Vac |
| Temperature inside enclosure: | 49°C (in the middle of the right side of the power supply with a distance of 2cm) |
| Temperature outside enclosure: | 24.3°C |
| Temperature rise: | 24.7K |

27.14. MOUNTING ORIENTATIONS

Mounting orientations other than input terminals on the bottom and output on the top require a reduction in continuous output power or a limitation in the max. allowed ambient temperature. The amount of reduction influences the lifetime expectancy of the power supply. Therefore, two different derating curves for continuous operation can be found below:

Curve A1 Recommended output current.

Curve A2 Max allowed output current (results approx. in half the lifetime expectancy of A1).

Fig. 27-12
Mounting Orientation A
Standard Orientation

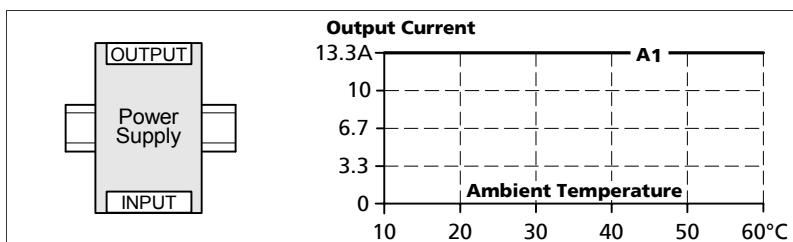

Fig. 27-13
Mounting Orientation B
(Upside down)

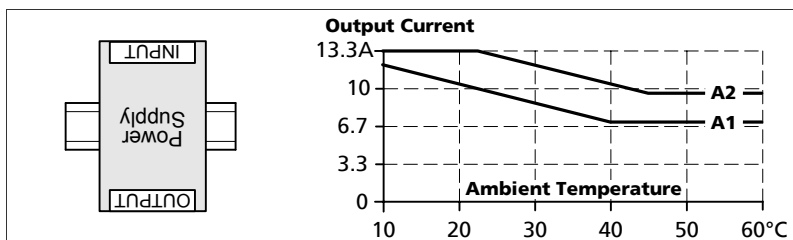

Fig. 27-14
Mounting Orientation C
(Table-top mounting)

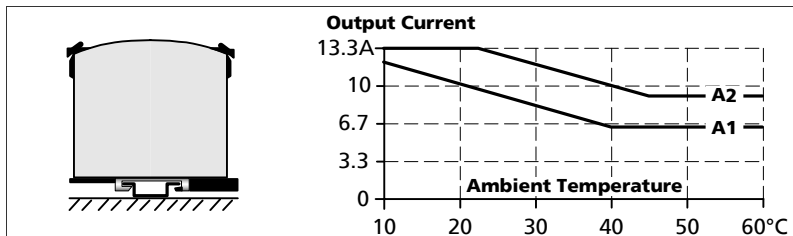

Fig. 27-15
Mounting Orientation D
(Horizontal cw)

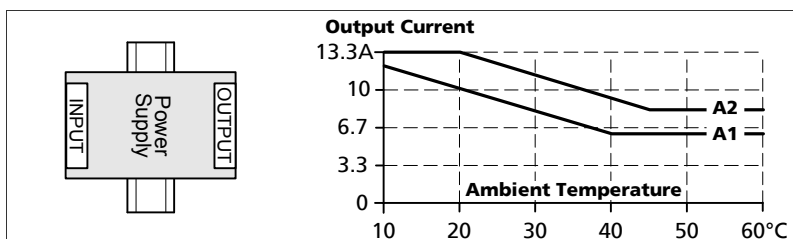

Fig. 27-16
Mounting Orientation E
(Horizontal ccw)

