



DC-UPS CONTROL UNIT

- Allows Batteries Between 3.9Ah and 130Ah
- Stable and adjustable Output Voltage in Buffer Mode
- Superior Battery Management for Longest Battery Life
- Comprehensive Diagnostic and Monitoring Functions
- Replace Battery Signal Included
- Battery Refreshing function
- Electronically Overload and Short Circuit Protected
- 3 Year Warranty

1. GENERAL DESCRIPTION

This uninterruptible power supply (UPS) controller UB20.241 is an addition to standard 24V power supplies to bridge power failures of voltage fluctuations. Expensive downtimes, long restart cycles and loss of data can be avoided.

The DC-UPS includes many diagnostic functions that ensure a reliable operation of the entire system. A unique feature of the UB20 Series is the constant voltage in buffer mode, which can be set to four different values. Another feature is the application of two independent battery chargers. This makes matching of batteries unnecessary and allows a precise battery charging, testing and optimized using of battery capacity to achieve the longest battery service life.

UB-Series
Related products

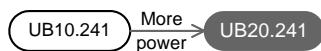

2. SHORT-FORM DATA

Input voltage range	nom. DC 24V 23.3Vdc- 30Vdc	
Output current	max. 25A min. 20A	Normal mode Buffer mode
Output voltage	nom. DC 24V Adjustable	Normal mode Buffer mode
Allowed batteries	2 x 12V 3.9Ah - 130Ah	VRLA lead acid
Temperature range Derating	-40 °C to +70 °C 0.5A/ °C	Operational +60 °C to +70 °C
Dimensions	46x124x127mm	WxHxD
Buffer time (at 20A)	8' 5" 15'	7Ah battery module 12Ah battery module

Typical setup of a DC-UPS system:

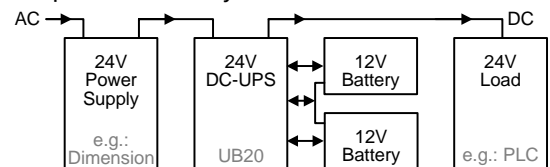

3. ORDER NUMBERS

DC-UPS	UB20.241	Controller
Accessory	UZK24.071	Battery module 24V/7Ah passiv
	UZK24.072	Battery module 24V/7Ah intelligent
	UZK24.121	Battery module 24V/12Ah passiv
	UZK24.122	Battery module 24V/12Ah intelligent

4. MARKINGS



November 2012 / Rev. 0.1 DS-UB20.241-EN preliminary
All parameters are specified at an input voltage of 24V, 20A output load, 25°C ambient and after a 5 minutes run-in time unless otherwise noted. It is assumed that the input power source can deliver a sufficient output current.

DIMENSION

INDEX PAGE

1. General Description	1
2. Short-form Data	1
3. Order Numbers	1
4. Markings	1
5. Input	3
6. Output in Normal Mode	3
7. Output in Buffer Mode	4
8. Battery Input	5
9. Buffer Time	6
10. Efficiency and Power Losses	7
11. Functional Diagram	7
12. Check Wiring and Battery Quality Tests	8
13. Relay Contacts and Inhibit Input	8
14. Front Side User Elements	9
15. Terminals and Wiring	10
16. EMC	11
17. Environment	12
18. Protection Features	13
19. Safety	13

INDEX PAGE

20. Dielectric Strength	14
21. Approvals	14
22. Fulfilled Standards	14
23. Physical Dimensions and Weight	15
24. Reliability	15
25. Installation Notes	16
26. Accessories	17
26.1. Battery Modules	17
26.2. ZM2.Wall - Wall Mounting bracket	18
26.3. ZM12.SIDE - Side Mounting bracket	19
27. Application Notes	19
27.1. Battery Replacement Intervals	19
27.2. Using the Inhibit Input	21
27.3. Connection of the Center Tap	22
27.4. Refresh function	22
27.5. Connection of an external temperature sensor	23
27.6. Output circuit breakers	23
27.7. Troubleshooting	24

INTENDED USE

The unit shall only be installed and put into operation by qualified personnel.

This unit is designed for installation in an enclosure and is intended for general use, such as in industrial control, office, communication, and instrumentation equipment. Do not use this device in aircraft, trains and nuclear equipment, where malfunctioning of the power supply may cause severe personal injury or threaten human life.

TERMINOLOGY AND ABBREVIATIONS

DC 24V	A figure displayed with AC or DC before the value represents a nominal voltage with standard tolerances (usually $\pm 15\%$) included
24Vdc	A figure displayed with the unit (Vdc) at the end is a momentary figure without any additional tolerances included
DC-UPS	Uninterruptible power supply with DC-Input.
Normal mode	Describes a condition where the battery is charged, the input voltage is in range and the output is loaded within the allowed limits.
Buffer mode	Describes a condition where the input voltage is below the transfer threshold level, the unit is running on battery (buffering) and the output is loaded within the allowed limits.
Charging mode	Describes a condition where the battery is being charged, the input voltage is in range and the output is loaded within the allowed limits.
Inhibit mode	Describes a condition where buffering is disabled on purpose by using the inhibit input of the DC-UPS. (e.g. for service actions, or to save battery capacity)
Buffer time	Same as the term "hold-up time".
T.b.d.	To be defined, value or description will follow later.

DISCLAIMER

The information presented in this document is believed to be accurate and reliable and may change without notice. No part of this document may be reproduced or utilized in any form without permission in writing from the publisher.

November 2012 / Rev. 0.1 DS-UB20.241-EN preliminary
 All parameters are specified at an input voltage of 24V, 20A output load, 25°C ambient and after a 5 minutes run-in time unless otherwise noted. It is assumed that the input power source can deliver a sufficient output current.

5. INPUT

Input voltage	nom.	DC 24V	
Input voltage ranges	nom.	23.3 to 30Vdc 30 to 35Vdc 35Vdc	Continuous operation, see Fig. 5-1 ¹ Temporarily allowed, no damage to the DC-UPS ² Absolute maximum input voltage with no damage to the DC-UPS
Threshold voltage for buffer-mode	typ.	Identical with buffer voltage	The DC-UPS switches into buffer mode and delivers output voltage from the battery if the input was above the turn-on level before and all other buffer conditions are fulfilled. ³
Turn-on voltage	typ.	23Vdc	The unit does not switch on if the input voltage does not exceed this level once.
	max	23.3Vdc	
Input current ⁴	typ.	70 mA	Internal current consumption for the DC-UPS Current consumption for battery charging in constant current mode at 24V input at battery selector position <10Ah at battery selector position >10Ah
	typ.	1.7A	
	typ.	3.4A	
External capacitors on the input		No limitation	

- 1) It is recommended, to set the input voltage min. 0.8V higher than the buffer voltage.
- 2) The DC-UPS shows "Check Wiring" with the red LED and buffering is not possible
- 3) The threshold depends on the selected buffer voltage.
- 4) The total input current is the sum of the output current, the current which is required to charge the battery during the charging process and the current which is needed to supply the DC-UPS itself. See also Fig. 5-2.

Fig. 5-1 Input voltage range

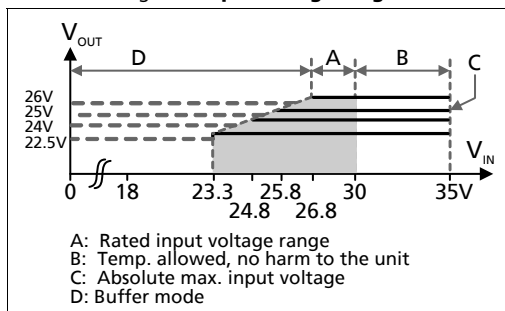
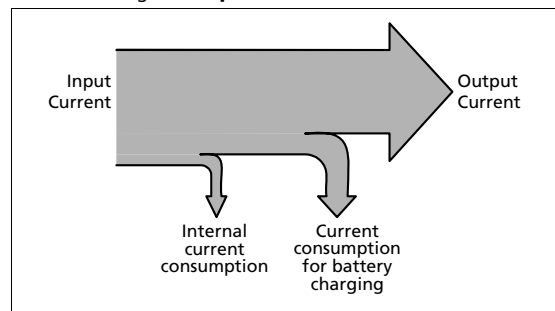

Fig. 5-2 Input current, definitions



6. OUTPUT IN NORMAL MODE

At normal operation the supplying source is connected to the output of the DC-UPS via a MOSFET. The output behavior in normal mode is the same as the supplying source. Please refer to the datasheet of the power supplies for detailed information. The maximum continuous allowed output current is 25A.

Output voltage in normal mode	typ.	0.15V lower as input voltage	At 20A output current
-------------------------------	------	------------------------------	-----------------------

Output power	nom.	600W	Continuously allowed
--------------	------	------	----------------------

If the rated output current of the supplying source is higher than 28A, it is necessary to use a 25A fuse (for example t. b. d.) between the power supply and the DC-UPS. In this case the max output current has to be reduced by the current consumption for battery charging to avoid nuisance tripping of the fuse.

November 2012 / Rev. 0.1 DS-UB20.241-EN preliminary
All parameters are specified at an input voltage of 24V, 20A output load, 25°C ambient and after a 5 minutes run-in time unless otherwise noted. It is assumed that the input power source can deliver a sufficient output current.

7. OUTPUT IN BUFFER MODE

If the input voltage falls below the transfer threshold level, the DC-UPS starts buffering without any interruption or voltage dips. Buffering is possible even if the battery is not fully charged.

Output voltage in buffer mode		22,5V, 24V, 25V, 26V	Output voltage is adjustable, stabilized and independent from battery voltage
Ripple and noise voltage	max	120mVpp.	20Hz to 20MHz, 50Ohm
Output current	nom.	20A 30A	Continuously allowed at 22.5V output voltage *) <4s with full output voltage
Short-circuit current	typ.	31A	Load impedance 50mOhm

*) Derating of the output current is necessary at higher output voltage. (19.5A at 24V, 18.5 at 25V, 18A at 26V) See Fig.: 7-1

BonusPower®, short term power capability (up to typ. 4s)

The UPS is designed to support loads with a higher short-term power requirement without damage or shutdown. The short-term duration is hardware controlled by an output power manager. This BonusPower® is repeatedly available. If the UPS is loaded longer with the BonusPower® than shown in the Bonus-time diagram (see Fig. 7-2), the max output current is automatically reduced to 20A.

If the current requirement is continuously above 30A and the voltage falls below approx. 18V (due to the current regulating mode at overload), the output shuts-off and makes periodical restart attempts. This behaviour is called hiccup mode which is described below. If the voltage is above 20V, the unit continuously delivers current.

Hiccup Mode:

Up to 4s of overloading, the UPS delivers continuous output current. After this, the output power is reduced to nearly zero for approx. 17s before a new start attempt is automatically performed. If the overload has been cleared, the device will operate normally. If the overload still exists, the output current will be delivered for 2 to 4s (depending on the overload) again followed by a 17s rest time. This cycle is repeated as long as the overload exists. See Fig. 7-3. During the off-period a small rest voltage and rest current is present on the output.

Output current	nom.	30A	see Fig. 7-1
Short-circuit current	min.	31A	load impedance 50mOhm, up to 4s, see Fig. 7-1
Bonus time	typ.	4s	duration until the output voltage dips, see Fig. 7-2
	min	3.5s	
	max	4.5s	

Fig. 7-1 Output voltage vs. output current, typ.

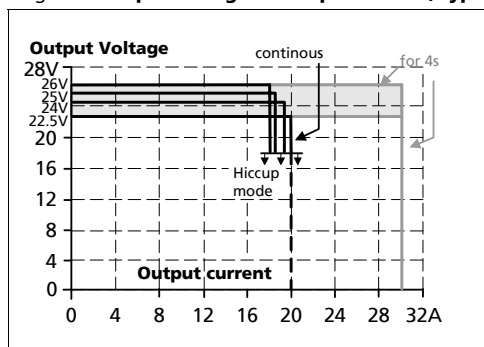
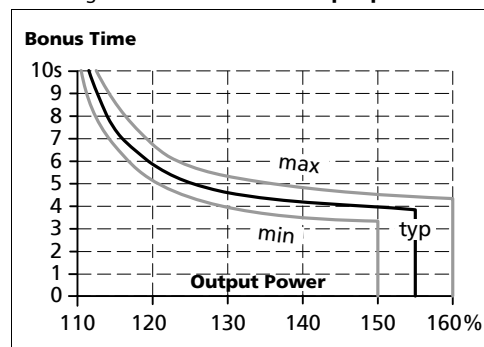
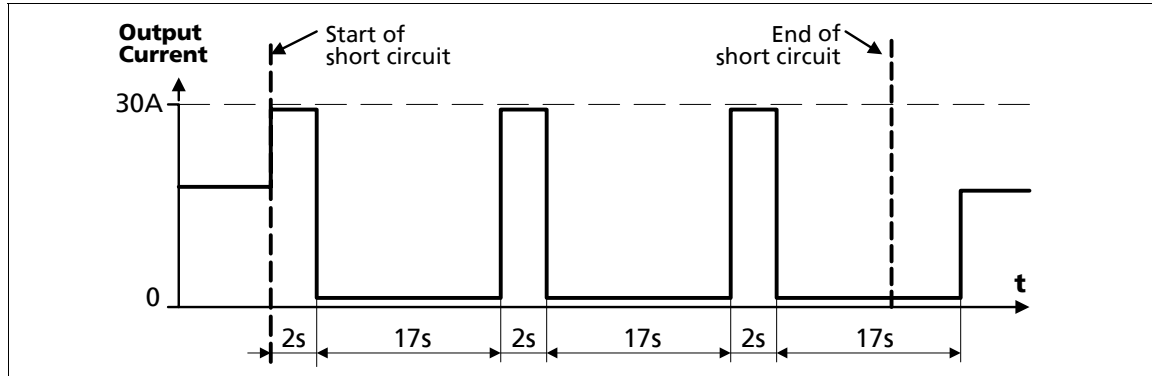

Fig. 7-2 Bonus time vs. output power



November 2012 / Rev. 0.1 DS-UB20.241-EN preliminary
 All parameters are specified at an input voltage of 24V, 20A output load, 25°C ambient and after a 5 minutes run-in time unless otherwise noted. It is assumed that the input power source can deliver a sufficient output current.

Fig. 7-3 Short-circuit on output, hiccup mode, typical behavior



8. BATTERY INPUT

The DC-UPS requires VRLA batteries with a sum voltage of 24V which is achieved by a series connection of two 12V batteries. To extend the service lifetime of the battery, the point of connection of the batteries can be connected with the center tap of the DC-UPS. (See chapter 27.3)

Battery voltage	nom.	2x DC 12V	Use two maintenance-free 12V VRLA lead acid batteries in series
Allowed battery sizes	min.	3.9Ah	At battery selector <10Ah
	max	130Ah	At battery selector position >10Ah
Battery charging method		CC-CV	Constant current, constant voltage mode
Battery charging current (CC-mode)	nom.	3.0A	at battery selector >10Ah, see also chapter 14
	max	3.2A	
	nom	1.5A	at battery selector <10Ah, see also chapter 14
	max	1.6A	
End-of-charge-voltage (CV-mode)		13.4V	If no temperature sensor is connected to the unit
		13.4-14.2Vdc*)	If an analog temperature sensor or PULS battery module is connected to the optional terminal
Battery charging time	typ.	8h**)	For a 12Ah battery
Deep discharge protection ***)	typ.	10.5V*)	At 0A output current
	typ.	9.0V*)	At 20A output current
Min. battery voltage	typ.	7.4Vdc*)	Above this voltage level battery charging is possible

*) These values are valid for each connected battery.

***) The charging time depends on the duration and load current of the last buffer event. The numbers in the table represent a fully discharged battery.

***) To ensure longest battery lifetime, the DC-UPS has a battery deep discharge protection feature included. The DC-UPS stops buffering when the voltage of one battery falls below a certain value.

9. BUFFER TIME

The buffer time depends on the capacity and performance of the batteries as well as the load current. The diagram below shows typical buffer times of the standard battery modules.

Buffer time with battery module UZK24.071	min.	13' 30"	At 10A output current *)
	min.	4' 10"	At 20A output current *)
	typ.	16' 53"	At 10A output current, see Fig. 9-1
	typ.	5' 12"	At 20A output current, see Fig. 9-1
Buffer time with battery module UZK24.121	min.	35' 30"	At 10A output current *)
	min.	11' 53"	At 20A output current *)
	typ.	44' 30"	At 10A output current, see Fig. 9-1
	typ.	14' 51"	At 20A output current, see Fig. 9-1

*) Minimum value includes 20% aging of the battery and a cable length of 1.5m with a cross section of 4mm² between the battery and the DC-UPS and requires a fully charged (min. 24h) battery.

Fig. 9-1 Buffer time vs. output current with battery modules UZK24.071 and UZK24.121

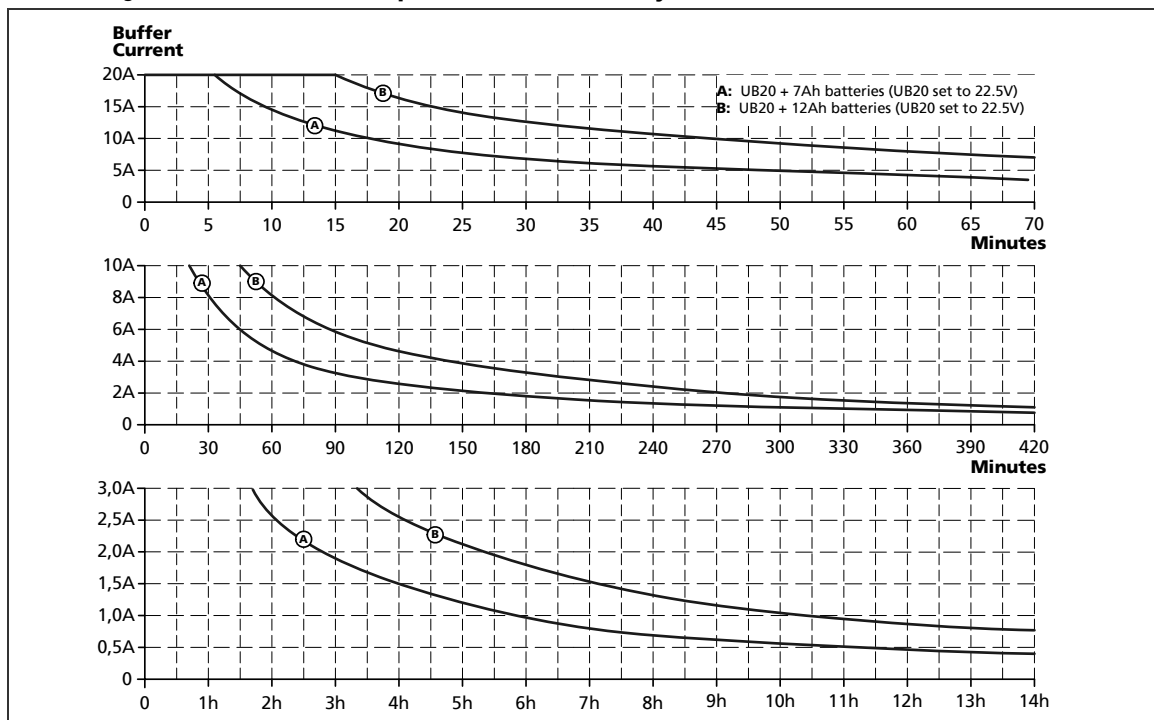

The battery capacity is usually specified in amp-hours (Ah) for a 20h discharging event. The battery discharge is non-linear (due to the battery chemistry). The higher the discharging current, the lower the appropriate battery capacity. The magnitude of the reduction depends on the discharging current as well as on the type of battery. High current battery types can have up to 50% longer buffer times compared to regular batteries when batteries will be discharged in less than 1 hour.

High discharging currents do not necessarily mean high power losses as the appropriate battery capacity is reduced with such currents. When the battery begins to recharge after a discharging event, the process is completed much faster since only the energy which was taken out of the battery needs to be "refilled".

For this reason, the buffer time cannot be calculated using the Ah capacity value. The equation "I x t" = capacity in Ah generally leads to incorrect results when the discharging current is higher than C20 (discharging current for 20h).

10. EFFICIENCY AND POWER LOSSES

Efficiency	typ.	99%	Normal mode, 20A output current, battery fully charged
Power losses	typ.	3.7W	Normal mode, 20A output current, battery fully charged
	typ.	7,8W	Buffer mode, 10A output current
	typ.	22,7W	Buffer mode, 20A output current

11. FUNCTIONAL DIAGRAM

Fig. 11-1 Functional diagram

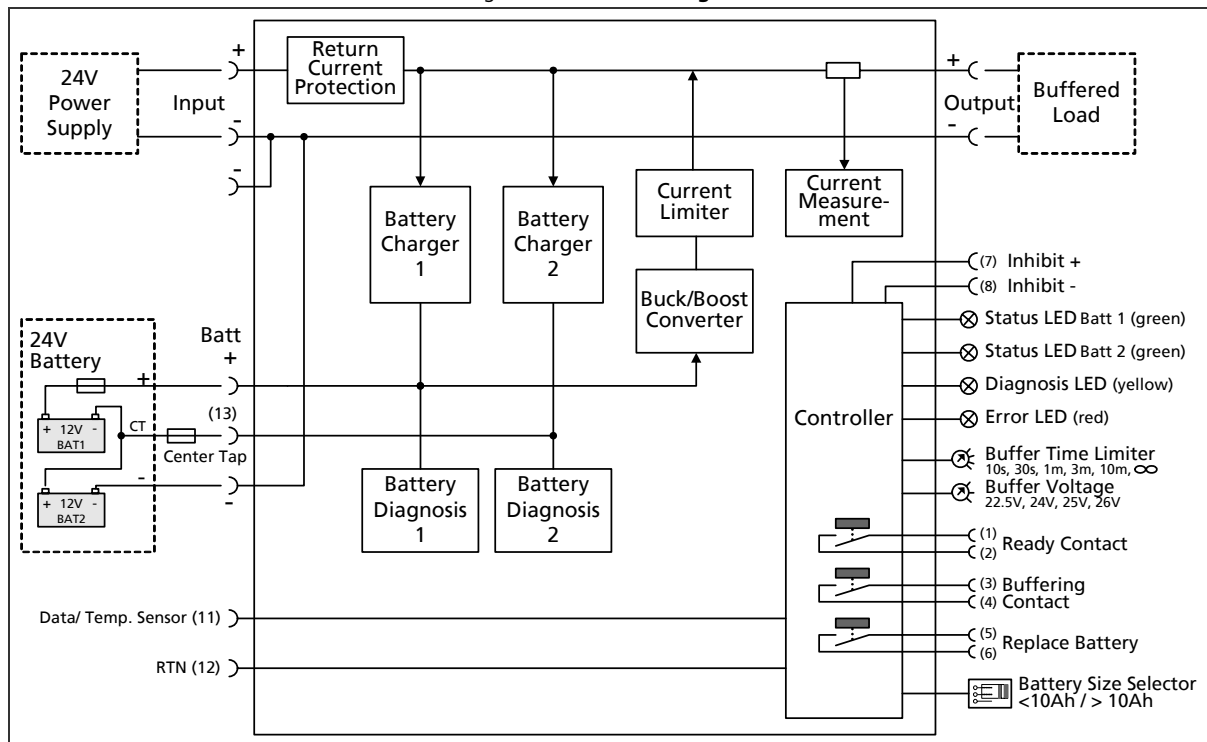

November 2012 / Rev. 0.1 DS-UB20.241-EN preliminary
 All parameters are specified at an input voltage of 24V, 20A output load, 25°C ambient and after a 5 minutes run-in time unless otherwise noted. It is assumed that the input power source can deliver a sufficient output current.

12. CHECK WIRING AND BATTERY QUALITY TESTS

The DC-UPS is equipped with an automatic "Check Wiring" and "Battery Quality" test.

"Check Wiring" test:

Under normal circumstances, an incorrect or bad connection from the battery to the DC-UPS or a missing (or blown) battery fuse would not be recognized by the UPS when operating in normal mode. In these cases the unit is not able to buffer if backup is required. To avoid this, a "check wiring" test is included in the DC-UPS. This connection is tested every 10 seconds by applying a load to the battery and analyzing the response from the battery. If the resistance is too high, or the battery voltage is not in range, the unit displays "Check Wiring" with the red LED. At the same time the green "Ready" LED will turn off.

"Battery Quality" or "State of Health" (SoH) test:

Batteries have a limited service life and need to be replaced in a fixed interval which is defined by the specified service life (acc. to the Eurobat guideline), based on the surrounding temperature and the number of charging/discharging cycles. If the battery is used longer than the specified service life, the battery capacity will degrade. Details can be found in chapter 27.1. The battery quality test can not determine a gradual loss in capacity. However, it can detect a battery failure within the specified service life of the battery. Therefore a battery quality test is included in the DC-UPS.

A battery problem is indicated with the yellow LED (replace battery pattern) and the green status LED of the affected battery (switched off). In addition to the indication of the UPS the relay contact "Replace Battery" will be closed. Please note that it can take up to 170 hours (with the largest size of battery) until a battery problem is reported. This should avoid nuisance error messages as any urgent battery problems will be reported by the "Check Wiring" test and create a warning signal.

When "Replace battery" is indicated, it is recommended to replace the affected battery as soon as possible.

13. RELAY CONTACTS AND INHIBIT INPUT

The DC-UPS is equipped with relay contacts and signal inputs for remote monitoring and controlling of the unit.

Relay contacts:

- Ready: Contact is closed when both batteries are charged more than 85%, no wiring failure is recognized, input voltage is sufficient and inhibit signal is not active.
- Buffering: Contact is closed when unit is buffering.
- Replace Battery: Contact is closed when the unit is powered from the input and the battery quality test (SOH test) of only one battery reports a negative result.

Relay contact ratings	Max	60Vdc 0.3A, 30Vdc 1A, 30Vac 0.5A resistive load
	Min	1mA at 5Vdc min.
Isolation voltage	Max	1000Vac, signal port to power port

Signal input:

- Inhibit: The inhibit input disables buffering. In normal mode, a static signal is required. In buffer mode, a pulse with a minimum length of 250ms is required to stop buffering. The inhibit is not stored. If the voltage on the inhibit input is lower than 6Vdc the unit continues buffering. See also section 27.2 for application hints.

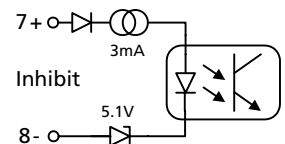

Signal voltage	Max.	35Vdc
Signal current	Max.	6mA, current limited
Inhibit threshold	Min.	6Vdc, buffering is disabled above this threshold level
	Max.	10Vdc
Isolation	Nom.	1000Vac, signal port to power port

November 2012 / Rev. 0.1 DS-UB20.241-EN preliminary
 All parameters are specified at an input voltage of 24V, 20A output load, 25°C ambient and after a 5 minutes run-in time unless otherwise noted. It is assumed that the input power source can deliver a sufficient output current.

14. FRONT SIDE USER ELEMENTS



A Signal Port

Plug connector with screw terminals, inserted from the surface. Connections for the Ready, Buffering, Replace Battery relay contacts and for the Inhibit input. See details in chapter 13.

B Power Port

Screw terminals, connection for input and output voltage

C Red Error LED

Check wiring: Failure in the installation, battery or battery fuse
Input voltage: Input voltage is lower than the selected Buffer voltage+0.8V

Temp: When the temperature of the battery is out of the specified values or to high temperature of the DC-UPS. See Fig. 14.1 for flashing pattern of the red error LED

D Yellow Diagnosis LED

Overload: Indicates if the Output current is higher than specified values.

Inhibit active: Indicates that buffering is disabled due to an active inhibit signal.

Buffer-time expired: Output has switched off due to settings of Buffer-time Limiter.

Replace battery: Indicates a battery which failed the battery quality (SoH test). Battery should be replaced soon. See Fig. 14.2 for flashing pattern of the yellow diagnosis LED

E Green Status LED's

Ready: Batteries are charged > 85%, no wiring failure is recognized, input voltage is sufficient and inhibit signal is not active.

Charging: Batteries are charging and the battery capacity is below 85%

Refreshing: Indicates an active refreshing function. (See Chapter 26.4)

Buffering: Unit is in buffer mode. See Fig. 14-3 for flashing pattern of the green status LED's

F Battery Size Selector

>10Ah: Charging current is set to 3A

<10Ah: Charging current is set to 1.5A

G Buffer-time Limiter:

User accessible dial which limits the maximum buffer time in a buffer event to save battery energy. Recharging of Batteries is much faster if only the necessary energy was taken out of the battery. Therefore the following buffer-times can be selected: 10 seconds, 30 seconds, 1 minute, 3 minutes, 10 minutes or infinity (until battery is flat) which allows buffering until the deep discharge protection stops buffering.

H Buffer-voltage Selector

The output voltage in buffer-mode can be adjusted to the four different values 22.5V, 24V, 25V, 26V.

I Battery Port

Screw terminals, connection for battery pack

J Optional Port

Plug connector with screw terminals, inserted from the bottom. Connection of temperature sensors or communication interface of intelligent battery modules and battery center tap

Fig. 14-1 Flashing pattern of the red error LED

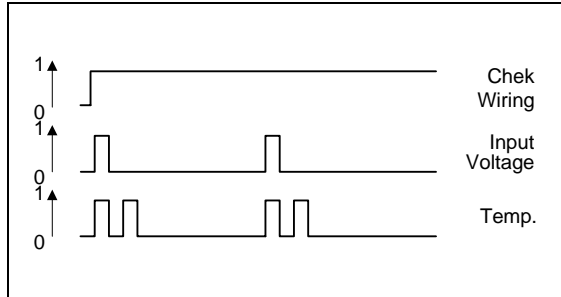

Fig. 14-2 Flashing pattern of the yellow Diagnosis LED

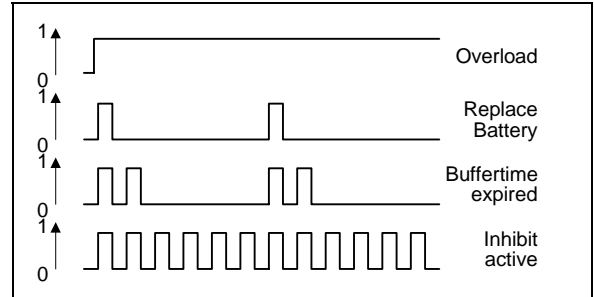
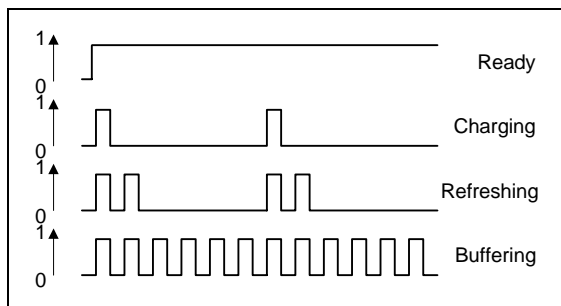

Fig. 14-3 Flashing pattern of the green status LED's



15. TERMINALS AND WIRING

	Power and battery terminals	Signal and optional terminals
Type	Screw terminals	Plug connector with screw terminal. Finger-touch-proof construction with captive screws for 3.5mm slotted screwdriver. Suitable for field- and factory installation. Shipped in open position. To meet GL requirements, unused terminal compartments should be closed.
Solid wire	2.5-6mm ²	0.2-1.5mm ²
Stranded wire	2.5-4mm ²	0.2-1.5mm ²
AWG	14-10AWG	22-14AWG
Ferrules	Allowed, but not required	Allowed, but not required
Recommended Tightening torque	0.8Nm, 7lb. in	0.4Nm, 3.5lb.in
Wire stripping length	7mm / 0.275inch	6mm / 0.24inch

Instructions:

- Use appropriate copper cables that are designed for an operating temperature of: 60°C for ambient temperature up to 45 °C and 75°C for ambient temperature up to 60 °C minimum.
- Follow national installation codes and installation regulations!
- Ensure that all strands of a stranded wire enter the terminal connection!
- Up to two stranded wires with the same cross section are permitted in one connection point.

November 2012 / Rev. 0.1 DS-UB20.241-EN preliminary
 All parameters are specified at an input voltage of 24V, 20A output load, 25°C ambient and after a 5 minutes run-in time unless otherwise noted. It is assumed that the input power source can deliver a sufficient output current.

16. EMC

The unit is suitable for applications in industrial environment as well as in residential, commercial and light industry environment without any restrictions. The CE mark indicates conformance with EMC directive 2004/108/EC, the low-voltage directive (LVD) 2006/95/EC and RoHS directive 2011/65/EC. A detailed EMC Report is available on request.

EMC Immunity	EN 61000-6-1, EN 61000-6-2	Generic standards		
Electrostatic discharge	EN 61000-4-2	Contact discharge	8kV	Criterion A*)
		Air discharge	15kV	Criterion A *)
Electromagnetic RF field	EN 61000-4-3	80MHz-2.7GHz	10V/m	Criterion A
Fast transients (Burst)	EN 61000-4-4	Out- and input lines	2kV	Criterion A
		Signal lines**)	2kV	Criterion A
Surge voltage	EN 61000-4-5	Output + → -	1kV	Criterion A
		Input + → -	1kV	Criterion B
		+ / - → earth(housing)	2kV	Criterion A
Conducted disturbance	EN 61000-4-6	0,15-80MHz	10V	Criterion A

Criteria:

A: DC-UPS shows normal operation behaviour within the defined limits

B: Output voltage is present without any interruption. For 2 sec buffer mode is activated followed by normal operation.

*) DIN-Rail earthed

***) Tested with coupling clamp

EMC Emission	EN 61000-6-3, EN 61000-6-4	Generic standards	
Conducted emission	IEC/CISPR 16-1-2, IEC/CISPR 16-2-1	Limits for DC ports according EN 61000-6-3	
Radiated emission	EN 55011, EN 55022	Class B	

This device complies with FCC Part 15 rules.

Operation is subjected to the following two conditions: (1) this device may not cause harmful interference, and (2) this device must accept any interference received, including interference that may cause undesired operation.

*) Informative measurement with voltage probe

Switching frequencies

The DC-UPS has three converters with the same switching frequency included.

Switching frequency of buck-boost converter and battery chargers	100kHz	Constant frequency
--	--------	--------------------

17. ENVIRONMENT

Operational temperature*)	-40°C to +70°C	Reduce output current according Fig. 17-1 and Fig 17-3 Battery charging between -10°C to +50°C**)
Storage temperature	-40°C to +85°C	Storage and transportation, except battery
Humidity***)	5 to 95% r.H.	IEC 60068-2-30 Do not energize while condensation is present
Vibration sinusoidal	2-17.8Hz: ±1.6mm; 17.8-500Hz: 2g 2 hours / axis	IEC 60068-2-6
Shock	30g 6ms, 20g 11ms 3 bumps / direction, 18 bumps in total	IEC 60068-2-27
Altitude	0 to 2000m (0 to 6560ft) 2000 to 6000m (6560 to 20000ft)	Without any restrictions
Altitude de-rating	1.25A/1000m or 5°C/1000	>2000m (6560ft), see Fig. 17-2 and Fig 17-4
Over-voltage category	III II	EN 50178 altitudes up to 2000m Altitudes from 2000m to 6000m
Degree of pollution	2	EN 50178, not conductive
LABS compatibility	The unit does not release any silicone or other LABS-critical substances and is suitable for use in paint shops.	

*) Operational temperature is the same temperature as the ambient temperature and is defined as the air temperature 2cm below the unit

***) Please be aware about battery specification.

***) Do not energize while condensation is present.

Fig. 17-1 Output current vs. ambient temperature in buffer mode

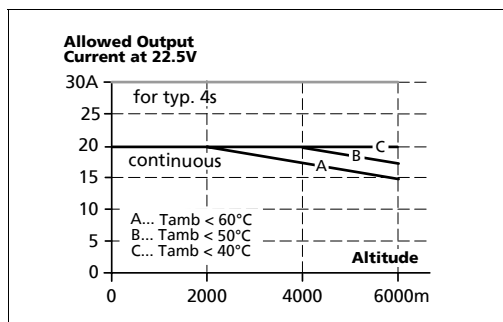

Fig. 17-2 Output current vs. altitude in buffer mode

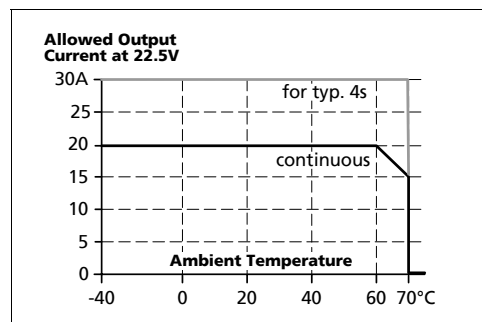

Fig. 17-3 Output current vs. ambient temperature in normal mode

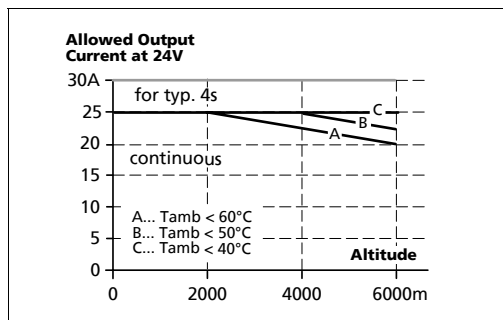
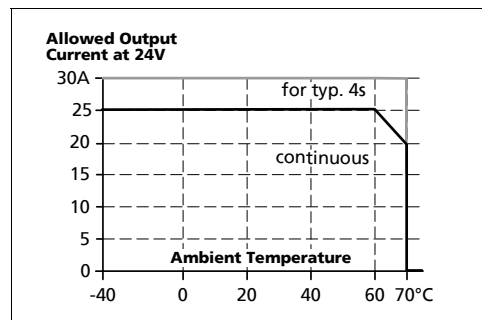

Fig. 17-4 Output current vs. altitude in normal mode



November 2012 / Rev. 0.1 DS-UB20.241-EN preliminary
All parameters are specified at an input voltage of 24V, 20A output load, 25°C ambient and after a 5 minutes run-in time unless otherwise noted. It is assumed that the input power source can deliver a sufficient output current.

18. PROTECTION FEATURES

Output protection	Electronically protected against overload, no-load and short-circuits	
Output over-voltage protection in buffer mode	typ. 32Vdc max. 35Vdc	In case of an internal defect, a redundant circuitry limits the maximum output voltage.
Degree of protection	IP20	EN/IEC 60529
Penetration protection	> 3.5mm	E.g. screws, small parts
Reverse battery polarity protection	yes	Max. -35Vdc;
Wrong battery voltage protection	yes	Max. +35Vdc
Battery deep discharge protection	yes	The limit is battery current dependent
Over temperature protection	yes	In buffer mode the output shuts-down with automatic restart
Internal input fuse	no	

19. SAFETY

Output voltage	SELV PELV Max. allowed voltage between any input, output or signal pin and ground: 60Vdc or 42.4Vac	IEC/EN 60950-1 EN 60204-1, EN 50178, IEC 60364-4-41
Class of protection	III	PE (Protective Earth) connection is not required
Isolation resistance	> 5MΩ	Power port to housing, 500Vdc

20. DIELECTRIC STRENGTH

The relay contacts and the inhibit input are floating and separated from the input and output voltage. The following isolation tests were performed.

Fig. 20-1 Dielectric strength

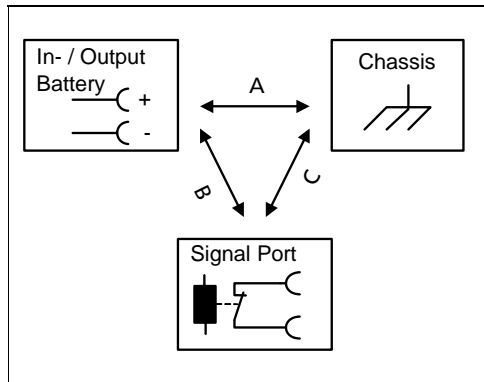

		A	B	C
Type test	60s	1000Vac	1000Vac	1000Vac
Factory test	5s	1000Vac	1000Vac	1000Vac
Field test	5s	500Vac	500Vac	500Vac
Cut off current setting		90mA	1mA	1mA

Type tests and factory tests:

Conducted by the manufacturer. Do not repeat test in field!

Rules for field test:

Use appropriate test equipment which applies the voltage with a slow ramp (2s up and 2s down). Connect input and output poles as well as the signal ports together. When testing, set the cut-off current settings to the value in the table above.

21. APPROVALS

EC Declaration of Conformity



The CE mark indicate conformance with the
 -EMC directive 2004/108/EC
 -low-voltage directive (LVD) 2006/95/EC and
 -RoHS directive 2011/65/EC.

UL 508
 pending



LISTED for use as Industrial Control Equipment;
 U.S.A. (UL 508) and Canada (C22.2 No. 107.1-01)
 E-File: E198865

UL 60950-1
 2nd Edition
 pending



RECOGNIZED for use as Information Technology Equipment,
 Level 5
 U.S.A. (UL 60950-1) and Canada (C22.2 No. 60950)
 E-File: E137006

IEC 60950-1
 2nd Edition
 pending



CB Scheme,
 Information Technology Equipment

22. FULFILLED STANDARDS

EN/IEC 60204-1	Safety of Electrical Equipment of Machines
EN/IEC 61131-2	Programmable Controllers
EN 50178, IEC 62103	Electronic Equipment in Power Installations

November 2012 / Rev. 0.1 DS-UB20.241-EN preliminary
 All parameters are specified at an input voltage of 24V, 20A output load, 25°C ambient and after a 5 minutes run-in time unless otherwise noted. It is assumed that the input power source can deliver a sufficient output current.

DIMENSION

23. PHYSICAL DIMENSIONS AND WEIGHT

Width	46mm / 1.81"	
Height	124mm / 4.88"	Plus height of signal connector plug
Depth	127mm / 5.0"	Plus depth of DIN-rail
Weight	700g / 1.54lbs	
DIN-Rail	Use 35mm DIN-rails according to EN 60715 or EN 50022 with a height of 7.5 or 15mm. The DIN-rail height must be added to the depth (117mm) to calculate the total required installation depth.	

Electronic files with mechanical data can be downloaded at www.pulspower.com

Fig. 23-1 Side view

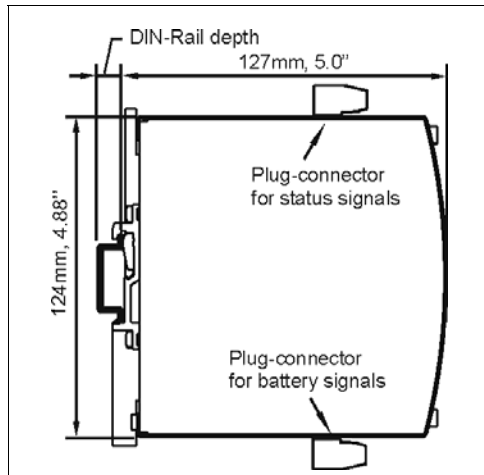
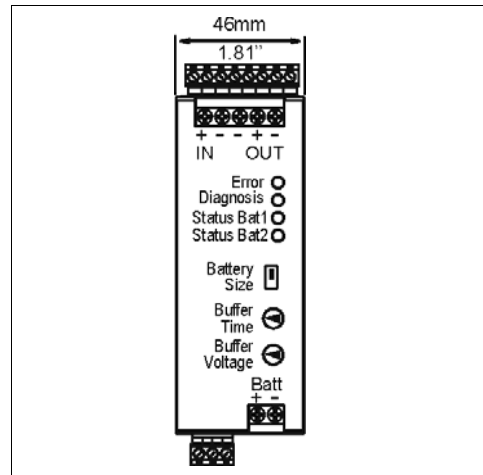

Fig. 23-2 Front view



24. RELIABILITY

Lifetime expectancy	min.	t.b.d.	At 20A output current, 40°C
	min.	t.b.d.	At 10A output current, 40°C
	min.	t.b.d.	At 20A output current, 25°C
	min.	t.b.d.	At 10A output current, 25°C
MTBF SN 29500, IEC 61709		t.b.d.	At 20A output current, 40°C
		t.b.d.	At 20A output current, 25°C
MTBF MIL HDBK 217F		t.b.d.	At 20A output current, 40°C, ground benign GB40
		t.b.d.	At 20A output current, 25°C, ground benign GB25

The **Lifetime expectancy** shown in the table indicates the operating hours (service life) and is determined by the lifetime expectancy of the built-in electrolytic capacitors. Lifetime expectancy is specified in operational hours. Lifetime expectancy is calculated according to the capacitor's manufacturer specification. The prediction model allows a calculation of up to 15 years from date of shipment.

MTBF stands for **Mean Time Between Failure**, which is calculated according to statistical device failures and indicates reliability of a device. It is the statistical representation of the likelihood of a unit to fail and does not necessarily represent the life of a product.

25. INSTALLATION NOTES

Mounting:

The power terminal shall be located on top of the unit. An appropriate electrical and fire end-product enclosure should be considered in the end use application.

Cooling: Convection cooled, no forced air cooling required. Do not obstruct air flow!

Installation clearances: 40mm on top, 20mm on the bottom

Risk of electrical shock, fire, personal injury or death!

Turn power off and disconnect battery before working on the DC-UPS. Protect against inadvertent re-powering. Make sure the wiring is correct by following all local and national codes. Do not open, modify or repair the unit. Use caution to prevent any foreign objects from entering into the housing. Do not use in wet locations or in areas where moisture or condensation can be expected.

Service parts:

The unit does not contain any service parts. If damage or malfunctioning should occur during operation, immediately turn power off and send unit to the factory for inspection!

Wiring and installation instructions:

- (1) Connect the power supply to the input terminals of the DC-UPS.
- (2) Connect two batteries in series. Connect the free battery terminals to the battery terminals and the center point to the center tap terminal of the DC-UPS (see Fig. 24-1). Do not install the batteries in airtight housings or cabinets. The batteries should be installed according to EN50272-2, which includes sufficient ventilation. Batteries store energy and need to be protected against energy hazards. Use a 30A fuse type ATO® 257 030 (Littelfuse) or similar in the battery path. Use an additional 4A fuse type ATO® 257 004 (Littelfuse) or similar between the center tap connection and the battery, if the center tap is connected. The battery fuses protect the wires between the batteries and the DC-UPS. It also allows the disconnection of the batteries from the DC-UPS which is recommended when working on the batteries or DC-UPS. Disconnect battery fuses before connecting the batteries.
Please note: Too small or too long wires between the DC-UPS and the batteries can shorten the buffer time or can result in a malfunction of the DC-UPS. Do not use wires smaller than 4.0mm² (or 12AWG) and not longer than 2x1.5m (cord length 1.5m). Avoid voltage drops on this connection.
- (3) Connect the buffered load to the output terminals of the DC-UPS. The output is decoupled from the input allowing load circuits to be easily split into buffered and non buffered sections. Noncritical loads can be connected directly to the power supply and will not be buffered. The energy of the battery can then be used in the circuits which require buffering.
- (4) Install the fuses when the wiring is finished.

Fig. 25-1 Typical wiring diagram

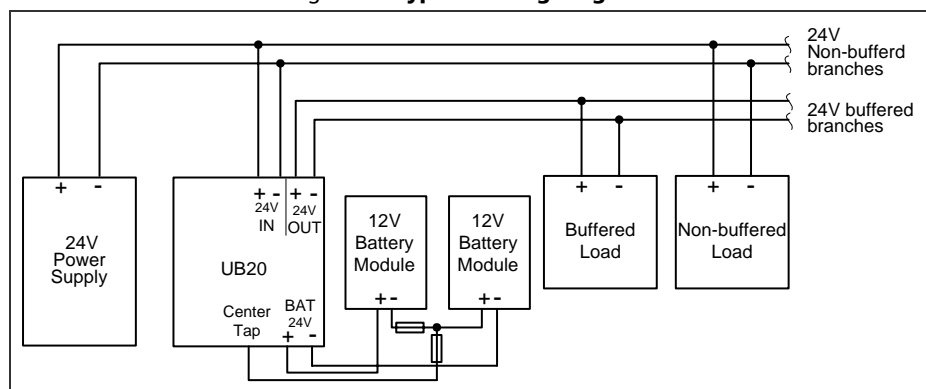

November 2012 / Rev. 0.1 DS-UB20.241-EN preliminary

All parameters are specified at an input voltage of 24V, 20A output load, 25°C ambient and after a 5 minutes run-in time unless otherwise noted. It is assumed that the input power source can deliver a sufficient output current.

26. ACCESSORIES

26.1. BATTERY MODULES

Depending on the requirements of the application two types of pre-assembled battery modules, intelligent or passive, with two different battery sizes are available. The passive battery modules include fuse holder, center tap fuse and a temperature sensor. The intelligent modules are equipped with a second temperature sensor, a data interface and allow battery refreshing. As an option, the mounting brackets are also available without batteries. This option offers more flexibility in selecting an appropriate battery or can save shipping and logistic costs. See individual data sheet for detailed information.

Module type	UZX24.071		UZX24.121		
	Passive		Intelligent		
Battery type	2x12V, 7Ah	2x12V, 12Ah	2x12V, 7Ah	2x12V, 12Ah	VRLA lead acid maintenance free battery
Service life	3 to 5 years	3 to 5 years	3 to 5 years	3 to 5 years	According to EUROBAT
Dimensions	137x193x130mm	203x193x130mm	137x184x173mm	203x184x173mm	Width x Height x Depth
Weight	t.b.d.	t.b.d.	6650g	10150g	
Order numbers	UZO24.071	UZO24.121	UZO24.072	UZO24.122	Mounting bracket without batteries
	2xUZB12.071	2xUZB12.121	2xUZB12.071	2xUZB12.121	Replacement battery only

Fig. 26-1

UZX24.071 24V/7Ah passive battery module



Fig. 26-2

UZX24.121 24V/12Ah passive battery module



Fig. 26-3 **UZK24.072**
24V/7Ah intelligent battery module



Fig. 26-4 **UZK24.122**
24V/12Ah intelligent battery module

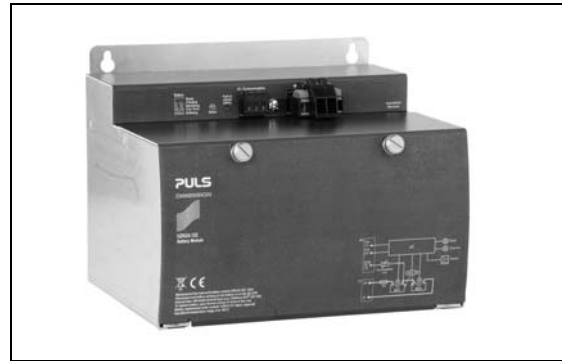

26.2. ZM2.WALL - WALL MOUNTING BRACKET

This bracket is used to mount the DC-UPS units onto a flat surface without utilizing a DIN-Rail.

Fig. 26-5 **Assembled Wall mounting bracket**

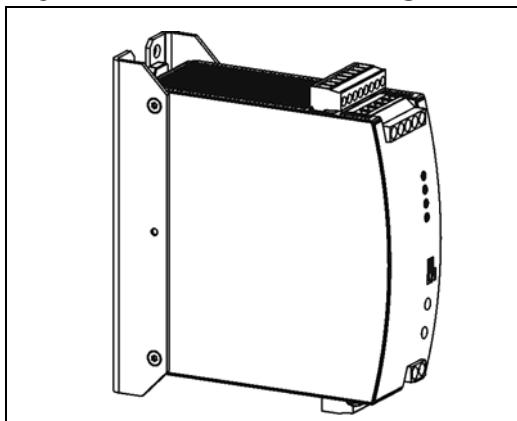

26.3. ZM12.SIDE - SIDE MOUNTING BRACKET

This bracket is used to mount the DC-UPS sideways with or without utilizing a DIN-Rail.

The two aluminum brackets and the black plastic slider of the unit have to be detached, so that the steel brackets can be mounted.

For side DIN-rail mounting, the removed aluminum brackets and the black plastic slider need to be mounted on the steel bracket.

Fig. 26-7

ZM12.SIDE Side mounting bracket

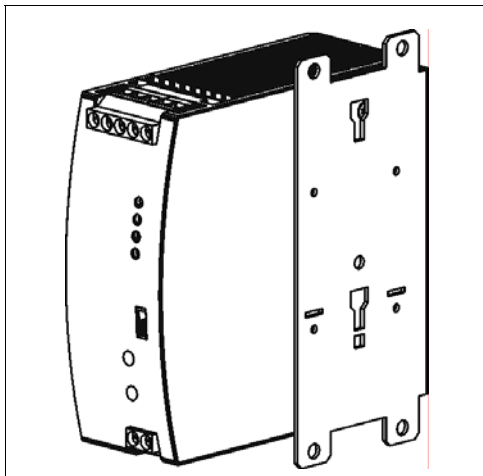
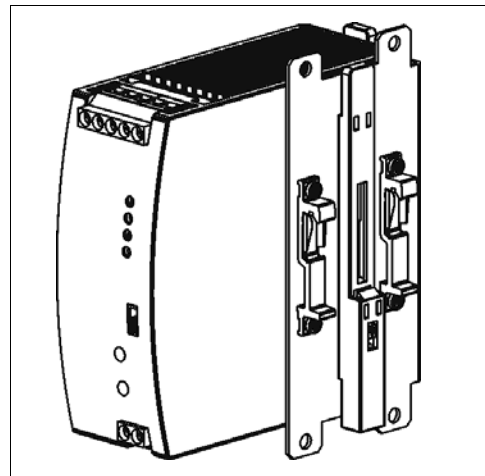

Fig. 26-8

Side mounting with DIN-rail brackets



27. APPLICATION NOTES

27.1. BATTERY REPLACEMENT INTERVALS

Batteries have a limited life time. They degrade slowly beginning from the production and need to be replaced periodically. The design life figures can be found in the individual datasheets of the batteries and usually is specified according to the Eurobat guideline or according to the manufacturer's specifications.

The design life is the estimated life based on laboratory condition, and is quoted at 20°C using the manufacturer's recommended float voltage condition. According to the Eurobat guideline, design lives have been structured into the following different groups:

- 3 - 5 years:** This group of batteries is very popular in standby applications and in small emergency equipment. This represents a 4 years design life with a production tolerance of ± 1 year.
- 6 - 9 years:** This group of batteries is usually used when an improved life is required. This represents a 7.5 years design life with a production tolerance of ± 1.5 years.
- 10 - 12 years:** This group of batteries is used when in applications where longest life and highest safety level are required. This represents a 11 years design life with a production tolerance of ± 1 year.

A battery failure within the specified design life of the battery usually results in a complete loss of the battery function (broken cell, defect connection, ...) and will be detected and reported by the periodical battery tests which are included in the UB20.241 DC-UPS control unit.

DIMENSION

If the operational parameters differ from those which are specified for the design life, an earlier change of the battery might be necessary. The "real life" is called service life and is defined as the point at which the cell's actual capacity has reached 80% of its nominal capacity. At the end of the service life the capacity degrades much faster, so that a further use of the battery is not recommended.

Temperature effect:

The temperature has the most impact in the service life. The higher the temperature, the earlier the wear-out phase of the battery begins. The wear-out results in a degradation of battery capacity. See Fig. 27-1 for details.

Effect of discharging cycles

The number as well as the depth of discharging cycles is limited. A replacement of the battery might be necessary earlier than the calculated service life if the battery exceeds the numbers and values of Fig. 27-2.

Other effects which shortens the service life

- Overcharging and deep discharging shortens the service life and should be avoided. Thanks to the two battery chargers of the UB20.241, the end-of-charge-voltage can be set very precisely to the required value and thereby avoiding unnecessary aging effects.
- Charge retention is important to get the longest battery life. Stored batteries which are not fully charged age faster than charged batteries. Batteries which are not in use should be recharged at least once a year.
- Excessive float charge ripple across the battery has an effect of reducing life and performance. The UB20.241 does not produce such a ripple voltage. This effect can be ignored when the battery is charged with the UB20.241.

Guidelines for a long battery service life:

- Place the batteries in a cool location: E.g. near the bottom of the control cabinet.
- Do not place the batteries near heat generating devices.
- Do not store discharged batteries.
- Do not discharge the batteries more than necessary. Set buffer time limiter to the required buffer time.
- When choosing the batteries capacity, always try to get the next higher capacity than required. The depth of discharge reduces the service life of the batteries and limits the number of cycles. See Fig. 27-2.

Example for calculating the service life and the required replacement cycle:Parameters for the example:

- two 26Ah battery with a design life of 10-12 years is used
- The average ambient temperature is 30°C
- One buffer event consumes approx. 25% of the achievable buffer time.
- One buffer event every two days

Calculation:

Ambient temperature influence:

According to Fig. 27-1 curve C, a 5 years service life can be expected for an ambient temperature of 30°C.

Number of discharging cycles: 5 years * 182 cycles = 910cycles in 5 years.

According to Fig. 27-2, curve C has to be used (only 25% of battery capacity is required). 910 cycles have only a negligible influence in a battery degradation and can be ignored.

Result:

The battery shall be replaced after 5 years.

Please note that the battery degrading begins from the production date (check date code on the battery) which may shorten the replacement intervals.

Fig. 27-1 Service life versus ambient temperatures, typ *)

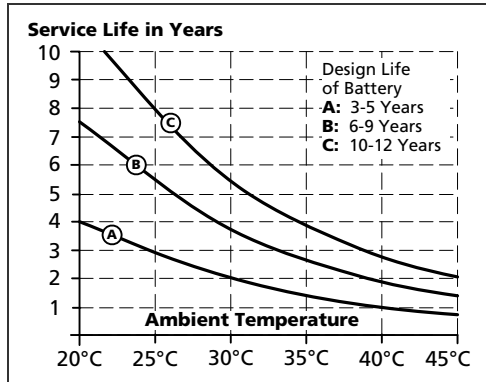
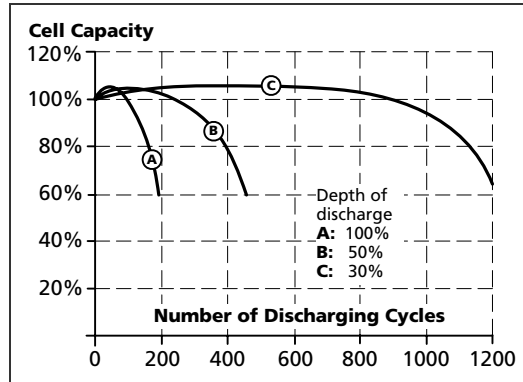

Fig. 27-2 Cell capacity degradation vs. discharging cycles *)



*) datasheet figures from battery manufacturer

27.2. USING THE INHIBIT INPUT

The inhibit input disables buffering. In normal mode, a static signal is required to avoid buffering. In buffer mode, a pulse with a minimum length of 250ms is required to stop buffering. The inhibit is not stored. If the voltage on the inhibit input is lower than 6Vdc the unit continues buffering.

As long as the inhibit signal is active in normal mode, an internal relay contact will be opened and the battery will not longer be charged.

For service purposes, the inhibit input can also be used to connect a service switch. Therefore, the inhibit signal can be supplied from the output of the DC-UPS.

Fig. 27-3 Wiring example for inhibit input

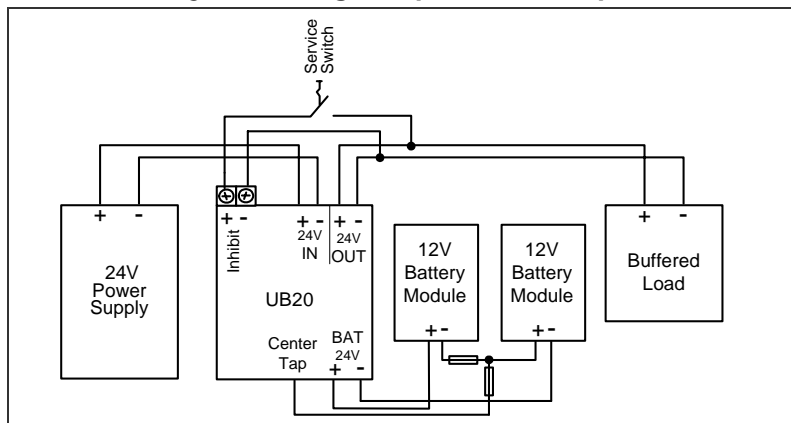

27.3. CONNECTION OF THE CENTER TAP

For optimized battery charging and testing the monitoring of every single battery is necessary. This ensures the longest service lifetime of the batteries. Therefore it is recommended to connect the centre point of both batteries with the center tap screw terminal of the UB20-241. Use an additional 4A fuse type ATO® 257 004 (Littelfuse) or similar between the DC-UPS and the battery (Fig.:27-4)

Fig. 27-4 **Typical wiring of the center tap**

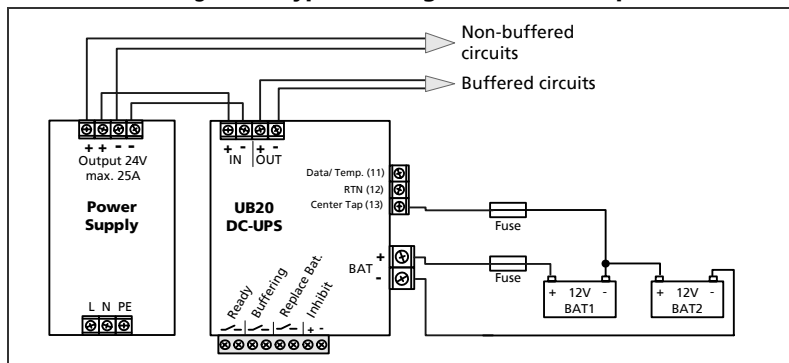

27.4. REFRESH FUNCTION

When the battery is not charged during a long time interval, the battery becomes deep-discharged due to the self discharge rate of lead acid batteries. The batteries cannot be charged with standard charging method and must be replaced. Therefore the UB20 is equipped with a refresh function. This function can be started and only works with intelligent battery modules. To avoid overcharging of good batteries or blowing up bad batteries each battery will be tested. If all tests pass certain criteria, a safe and controlled overcharging of the batteries starts. This test will be repeated after every refresh process. Maximum 5 refresh cycles per battery are possible. If the battery cannot be refreshed during these cycles the battery will be indicated as defective. The Refresh process can be interrupted by pulling the optional plug and the power terminal of the battery module.

Fig. 27-5 **Time schedule of the refresh function**

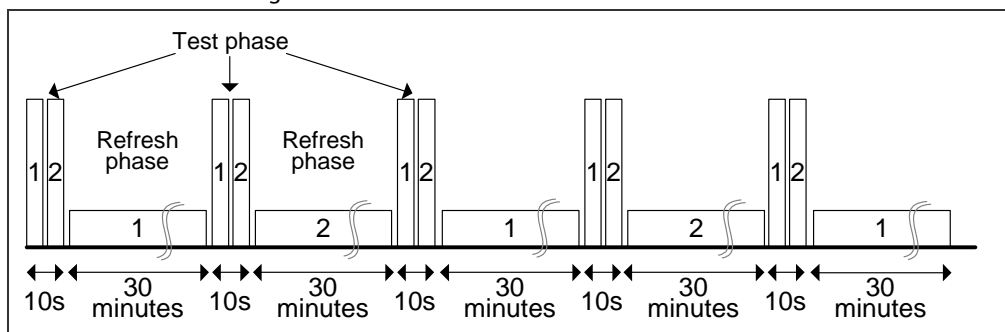

November 2012 / Rev. 0.1 DS-UB20.241-EN preliminary
All parameters are specified at an input voltage of 24V, 20A output load, 25°C ambient and after a 5 minutes run-in time unless otherwise noted. It is assumed that the input power source can deliver a sufficient output current.

27.5. CONNECTION OF AN EXTERNAL TEMPERATURE SENSOR

The end of charge voltage of VRLA batteries depends on the environmental temperature. This affects the lifetime of the batteries. To avoid overcharging at higher temperatures it is recommended to adapt the end of charge voltage to the environmental temperature. For temperature compensated battery charging it is necessary to connect an external temperature sensor (PT1000) between "Data/Temp" (pin 11) and "RTN" (pin 12) of the DC-UPS. PULS battery modules are equipped with an internal temperature sensor already. A list of recommend temperature sensors is available on the PULS website if other batteries will be used.

The end of charge voltage is set to a fixed value of 13.4V if no temperature sensor is connected.

27.6. OUTPUT CIRCUIT BREAKERS

Standard miniature circuit breakers (MCB's or UL 1077 circuit breakers) are commonly used for AC-supply systems and may also be used on 24V branches.

MCB's are designed to protect wires and circuits. If the ampere value and the characteristics of the MCB are adapted to the wire size that is used, the wiring is considered as thermally safe regardless of whether the MCB opens or not. To avoid voltage dips and under-voltage situations in adjacent 24V branches which are supplied by the same source, a fast (magnetic) tripping of the MCB is desired. A quick shutdown within 10ms is necessary corresponding roughly to the ride-through time of PLC's. This requires units with high current reserves and large output capacitors.

Furthermore, the impedance of the faulty branch must be sufficiently small in order for the current to actually flow. The best current reserve in the supplying source does not help if Ohm's law does not permit current flow. The following table has typical test results showing which B- and C-Characteristic MCBs magnetically trip depending on the wire cross section and wire length.

Please be aware, that the values in the table below are only valid for buffer mode. In normal mode the supplying source defines these values. Please refer to the datasheet of the supplying source for further information.

Fig. 27-6 Test circuit

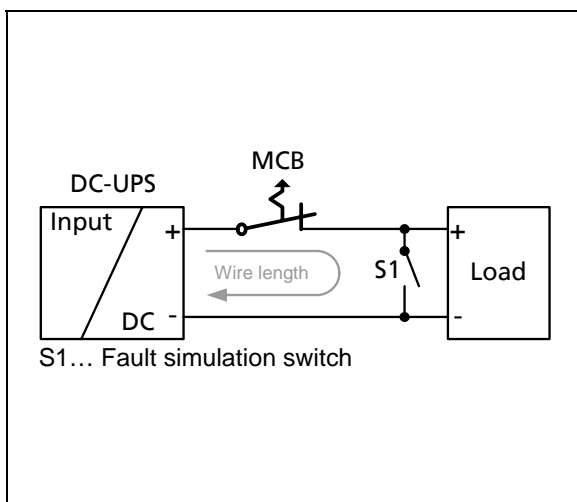

Maximal wire length*) for a fast (magnetic) tripping:

	0.75mm ²	1.0mm ²	1.5mm ²	2.5mm ²
C-2A	t. b. d.	t. b. d.	t. b. d.	t. b. d.
C-3A	t. b. d.	t. b. d.	t. b. d.	t. b. d.
C-4A	t. b. d.	t. b. d.	t. b. d.	t. b. d.
C-6A	t. b. d.	t. b. d.	t. b. d.	t. b. d.
C-10A	t. b. d.	t. b. d.	t. b. d.	t. b. d.
C-13A	t. b. d.	t. b. d.	t. b. d.	t. b. d.
B-6A	t. b. d.	t. b. d.	t. b. d.	t. b. d.
B-10A	t. b. d.	t. b. d.	t. b. d.	t. b. d.
B-13A	t. b. d.	t. b. d.	t. b. d.	t. b. d.
B-16A	t. b. d.	t. b. d.	t. b. d.	t. b. d.

27.7. TROUBLESHOOTING

The LEDs on the front of the unit and relay contacts indicate about the actual or elapsed status of the DC-UPS. Please see also chapter 14.

The following guidelines provide instructions for fixing the most common failures and problems. Always start with the most likely and easiest-to-check condition. Some of the suggestions may require special safety precautions. See notes in section 25 first.

"Error" LED is flashing	Check input and buffer voltage (input voltage must be min. 0.8V higher than buffer voltage)
"Error" LED is on	Check correct wiring between the battery and the DC-UPS Check battery fuse. Is the battery fuse inserted or blown? Check battery voltage (must be typically between 14.8V and 30V) Check battery polarity
DC-UPS did not buffer	Inhibit input was set Battery did not have enough time to be charged and is still below the deep discharge protection limit.
DC-UPS stopped buffering	Deep discharge protection stopped buffering → use a larger battery, or allow sufficient time for charging the battery
Output has shut down	Cycle the input power to reset the DC-UPS Let DC-UPS cool down, over temperature protection might have triggered.
DC-UPS constantly switches between normal mode and buffer mode	The supplying source on the input is too small and can not deliver sufficient current → Use a larger power supply or reduce the output load