



100W/200W



360W

- Full Galvanic Isolation
- Corrosion Resistant Case
- Fully regulated and filtered output
- Wide input range
- Various input and output combinations
- Some models may be used for battery charging
- Suitable for use with radio equipment

SPECIFICATIONS All specifications are typical at nominal input, full load and at 20°C unless otherwise stated.

MODEL NUMBERS				
MODEL	Vin	Vout	I out	Power
OR2-100-1212	12V (9-18VDC)	12.5V	8A	100W
OR2-100-2412	24V (20-35VDC)	12.5V	8A	100W
OR2-100-4812	48V (30-60VDC)	12.5V	8A	100W
OR2-100-9612	96V (60-120VDC)	12.5	8A	100W
OR2-100-1224	12V (9-18VDC)	24V	4A	100W
OR2-100-2424	24V (20-35VDC)	24V	4A	100W
OR2-100-4824	48V (30-60VDC)	24V	4A	100W
OR2-100-9624	96V (60-120VDC)	24V	4A	100W
OR2-200-1212	12V (9-18VDC)	12.5V	16A	200W
OR2-200-2412	24V (20-35VDC)	12.5V	16A	200W
OR2-200-4812	48V (30-60VDC)	12.5V	16A	200W
OR2-200-9612	96V (60-120VDC)	12.5V	16A	200W
OR2-200-1224	12V (9-18VDC)	24V	8A	200W
OR2-200-2424	24V (20-35VDC)	24V	8A	200W
OR2-200-2448	24V (20-35VDC)	48V	4A	200W
OR2-200-4824	48V (30-60VDC)	24V	8A	200W
OR2-200-4848	48V (30-60VDC)	48V	4A	200W
OR2-200-9624	96V (60-120VDC)	24V	8A	200W

MODEL NUMBERS				
MODEL	Vin	Vout	I out	Power
OR2-360-1212V2	12V (9-18VDC)	12.5V	30A	360W
OR2-360-2412V2	24V (20-35VDC)	12.5V	30A	360W
OR2-360-4812V2	48V (30-60VDC)	12.5V	30A	360W
OR2-360-9612	96V (60-120VDC)	12.5V	30A	360W
OR2-360-1224V2	12V (9-18VDC)	24V	15A	360W
OR2-360-2424V2	24V (20-35VDC)	24V	15A	360W
OR2-360-2448	24V (20-35VDC)	48V	7.5A	360W
OR2-360-4824V2	48V (30-60VDC)	24V	15A	360W
OR2-360-4848V2	48V (30-60VDC)	48V	7.5A	360W
OR2-360-9624	96V (60-120VDC)	24V	15A	360W
OR2-360-11012	110V (70-135VDC)	12.5V	28A	360W
OR2-360-11024V2	110V (70-135VDC)	24V	15A	360W
OR2-330-1227C	12V (9-18VDC)	27.6V	12A	330W
OR2-38-(7-35)12	12/24V (7-35VDC)	12.6V	3A	38W



100W/200W



360W

360W models
Version 1



360W models
Version 2

100W , 200W models

MODEL	OR2-100W	OR2-200W	OR2-360W
Power rating (W)	100W (12,5V/8A or 24V/4A)	200W (12,5V/16A or 24V/8A)	360W (12,5V/30A or 24V/15A)
Galvanic isolation	yes	yes	yes
Temperature increase after 30 minutes at full load (°C)	25	30	30
Fan assisted cooling (temp. controlled)	no	yes	yes
Weight kg (lbs)	0,5	0,6	1,4
Dimensions hxxwxd in mm	49 x 88 x 152	49 x 88 x 182	Version 1: 64 x 163 x 160 Version 2: 83 x 133 x 191

Instructions for installation of the OR2 DC/DC converters:

The converter must be mounted securely in a cool, dry location. Connect the negative input leads to the minus terminal on the converter. Attention: A bad minus connection could make the output voltage equal to the input voltage! Then connect the input lead via a fuse to the input terminal. At this point make sure that the output voltage is OK. If it is, you may safely connect the equipment to the OUT terminal via a fuse. (Fuse value equal to the output current). Attention: The currents can be very high. Always use cables of sufficient diameter! If no input and output fuse are used then warranty is void.

OR2-38-(7-35)-12 : Very wide input converter model
Input 7 – 35 V, output 12,6 V current limit 3 A, derate current linearly from 3 A at 18 V to 1,5 A at 7 V
Weight 1,4 kg , dimensions 64 x 163 x 160 mm

OR2-330-1227C : Battery Charger model
Input 9 – 18 V, output 27,6 V, current limit 12 A, fan assisted cooling
Output voltage adjustable with potentiometer
Weight 1,4 kg , dimensions 64 x 163 x 160 mm

Common Characteristics	
Output voltage tolerance	3 %
Output noise	< 50 mV rms
Off load current	< 25 mA
Efficiency	85%
Isolation	> 400 Vrms between input, output and case
Operating temperature	- 20 to + 30°C (0 to 90°F). Derate linearly to 0 A at 70°C (160°F)
Humidity	Max 95% non condensing
Casework	Anodised aluminum
Connections	6.3 mm (2.5 inch) push-on flat blade connectors
Protection: Overcurrent Overheating Reverse polarity conn.	Short circuit proof Reduction of output voltage Fuse and reverse connected diode across input
Overvoltage	Varistor (also protects against load dump)
Standards: Emission	EN 50081-1
Immunity	EN 50082-1
Automotive Directive	95/45/EC

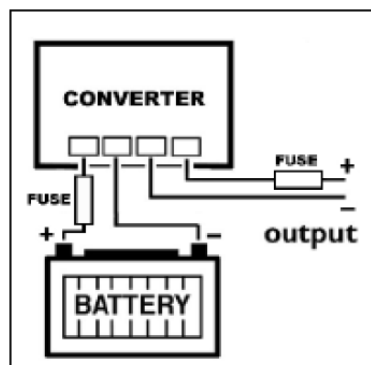

Application Note for OR2-360 models:

If the converter is to be used in a forklift application with an input of 30V or higher , it is recommended to use a diode in series with the input. Supplied with each converter is a diode , this diode can be connected between the battery and the input to the converter as shown in the the diagram below.

